

**INSTALLATION
INSTRUCTIONS**

FA120C Security System



**This Security System Can Support
6 EOLR WIRED ZONES
and
(when used with appropriate wireless receiver or wired expansion unit)
UP TO A TOTAL OF 16 EXPANSION ZONES
(up to 16 wireless or 8 additional wired zones)**

**THIS ISSUE HAS BEEN REFORMATTED
FOR EASIER READING AND INSTALLATION.
IT ALSO CONTAINS INFORMATION
ON SYSTEM ENHANCEMENTS NOW INCLUDED**

CONGRATULATIONS! **On Your Purchase of the FA120C**

The purpose of these Installation Instructions is to give you a complete overview of the system, and provide instructions for installing a basic system.

CONTACTING TECHNICAL SUPPORT

PLEASE,

Before you call Technical Support, be sure you:

- **READ THE INSTRUCTIONS!**
- **Check all wiring connections.**
- **Determine that the power supply and/or backup battery are supplying proper voltages.**
- **Verify your programming information where applicable.**
- **Note the proper model number of this product, and the version level (if known) along with any documentation that came with the product.**
- **Note your customer number and/or company name.**

Having this information handy will make it easier for us to serve you quickly and effectively.

You may contact Technical Support via Toll Free Fax. Please include your return Fax number. You will receive a reply within 24 hours. You may also contact Technical Support via modem to ATLLIS-BBS, Tech Support's Electronic Bulletin Board System. Replies are posted within 24 hours.

Premier Gold Technical Support: 1-800-538-5585 (8 a.m.-6 p.m. E.S.T.)

After 6 p.m. E.S.T.: 1-800-421-5557

Please be sure you have your PIN number ready before calling.

Technical Support Fax Number: 1-800-447-5086

*ATLLIS-BBS Electronic Bulletin Board System: 1-516-496-3980
(1200 - 9600 Baud, 8 Data Bits, 1 Start/Stop Bit, No Parity)*

<p>FOR YOUR CONVENIENCE, two easily removable Programming Forms have been included at the center of this manual.</p>

TABLE OF CONTENTS

Section 1. GENERAL INFORMATION.....	4	TRUBLE CONDITIONS.....	15
Introduction	4	General Information	15
Zone Characteristics.....	5	"Check" and "Battery" Displays	15
Section 2. SYSTEM CONFIGURATIONS.....	6	Power Failure.....	15
ZONE RESPONSE TYPE DEFINITIONS	6	Other Displays (Fixed Word Keypads)	15
HARD WIRED ZONES.....	7	Section 6. PROGRAMMING THE SYSTEM.....	16
Basic Control's Zones	7	General Information	16
WIRED ZONE EXPANSION	7	Summary of Programming Commands.....	17
No. 4219 Wired Expansion Unit	7	Special Messages.....	17
WIRELESS EXPANSION, —5700 RF SYSTEM—.....	8	PROGRAMMING DATA FIELDS.....	18
General.....	8	Section 7. SYSTEM COMMUNICATION.....	23
Supervision.....	8	Report Code Formats	23
House Identification.....	8	Section 8. REMOTE PROGRAMMING AND	CONTROL (DOWNLOADING).....
Transmitter Identification.....	8	General Information	24
Section 3. MOUNTING THE CONTROL,	LOCK, & PC BOARD	Equipment Required.....	24
Mounting the Cabinet	9	Programming.....	24
Installing the Lock (if Used).....	9	Remote Programming Advisory Notes.....	25
Installing the Control's Circuit Board Alone,	or (if used), with a 4219.....	Section 9. TESTING THE SYSTEM.....	26
Installing Control and RF Receiver Circuit Boards	Together, in the Same Cabinet	Procedure.....	26
.....	10	Section 10. SPECIFICATIONS &	ACCESSORIES
Section 4. WIRING & POWERING	THE SYSTEM	SPECIFICATIONS.....	29
Grounding the System.....	11	ACCESSORIES (COMPATIBLE DEVICES).....	30
Terminals and Connections	11	FCC STATEMENTS	34
Power-up Procedure	12	CANADIAN DOC STATEMENT	35
Section 5. SYSTEM OPERATION	13	LIMITATIONS OF THIS ALARM SYSTEM	36
SECURITY CODES.....	13	LIMITED WARRANTY	37
Master Code.....	13	<u>Diagrams and Tables</u>	
User Codes.....	13	TROUBLESHOOTING GUIDE	27
KEYPAD FUNCTIONS	13	DIP SWITCH TABLES FOR	WIRELESS DEVICES.....
General Information.....	13	SUMMARY OF CONNECTIONS DIAGRAM.....	33
Arming Functions	14	PROGRAMMING FORM.....	Centerfold
Keyswitch Operation (if Installed).....	14		
Panic Keys	14		

Section 1. GENERAL INFORMATION

Introduction

System	The FA120C is a microprocessor-based state-of-the-art security control intended for wireless applications.
Zones Supported	<p>Supports up to 22 zones, in the following configuration:</p> <ul style="list-style-type: none"> • 6 hard wired EOLR "basic" zones and either • Up to 16 wireless zones by using an appropriate RF receiver (4281 type) or Up to 8 additional hard wired EOLR zones by using a wired expansion unit (No. 4219). <p>Refer to the Zone Characteristics chart on the next page for detailed zone information.</p> <p>Note: The <i>single</i> 4281 type RF receiver that the FA120C accommodates, features Spatial Diversity (dual antennas), which virtually eliminates the possibility of "Nulls" and "Dead Spots" within the coverage area.</p>
Programming	<p>The system can be easily programmed from any of the remote keypads listed below.</p> <p>Programmed options to establish specific alarm and reporting features are stored in electrically erasable, non-volatile EEROM memory. This means that the unit can be reprogrammed many times (unlike units equipped with PROMs) and that information which has been programmed will not be lost in the event of a complete loss of power.</p> <p>In addition, the system can be uploaded, downloaded, or controlled via a computer and Hayes modem (see <i>REMOTE PROGRAMMING AND CONTROL</i> on page 24).</p>
Remote Keypads	<p>The system may use one or more FA200KP, FA250KP, FA310KP or Ademco 5330 Keypads. The first three have digital keypads and fixed English status LCDs. The 5330 provides programmable English language zone descriptors and status indications (select for Vector device, as described in the 5330's installation instructions).</p> <div style="border: 1px solid black; padding: 5px; margin: 5px 0;"> <p>Note: FA250KP and FA310KP (Addressable) Keypads must be set to their non-addressable mode (device ID 31).</p> </div> <p>When wireless is in use, the system may also be armed and disarmed with a wireless keypad (Ademco No. 5727).</p> <p>When neither wireless nor a 4219 Wired Expansion Unit is used, the system may also be armed and disarmed with a keyswitch (Ademco No. 4116).</p>
User Codes	Up to 3 secondary user codes can be assigned by the system's Master code.
Communication	The system provides communication capability (central station reporting, etc.) over existing telephone lines.

Alarm Output Advisory

This system includes an alarm output rated at 2 amps. Throughout the manual, wherever reference is made to Alarm Output Ratings, they assume a fully charged battery is connected, unless the UL rating is stated. The battery is periodically tested automatically (approximately every four hours), and if it cannot sustain a load, a low battery message is displayed and can be reported to the central station.

Multiple Keypads

(up to 4...see page 11) may be used, as long as their total current drain is within the alarm and auxiliary power output limitations described in the *SPECIFICATIONS AND ACCESSORIES* section.

Zone Characteristics

<p>Zones 1-6 For more information, see page 7.</p>	<p>Wired Programmable Zones. EOLR supervised, N.O. or N.C. sensors, 300-500 msec normal response.</p>								
<p>Zones 7, 95, 96 For more information, see page 14.</p>	<p>Keypad Panics (Wired & Wireless). 24hr zones. Zone 7 is programmable for silent, audible, auxiliary, or fire. Zones 95 (Silent Panic) and 96 (Audible Panic) are fixed-function zones.</p>								
<p>Zone 8</p>	<p>Duress (see User's Manual).</p>								
<p>Zone 9</p>	<p>Tamper. Reports faults in the 4281 RF receiver and trouble-by-day/alarm-by-night zones. For all report formats (except Contact ID, which provides more explicit reporting) a trouble code is reported when the system is not armed, and Zone 9 report code is sent for an alarm.</p>								
<p>Additional Wired Programmable Zones For more information, see page 7.</p> <p>or</p> <p>Wireless Zones For more information, see page 8.</p>	<p>Up to 8 loops can be added, with a 4219 Wired Expansion Unit. Loops are EOLR supervised, for N.O. or N.C. sensors, 300-500 msec normal response, with optional fast (10-15 msec) response on loop A (first expansion zone). Zone number assignments can be in the 10-63 range, with the assigned zone number determining the zone type.</p> <p>Up to 16 wireless (RF) zones can be added by using an Ademco 4281(5700 System) Type RF Receiver. Specifically:</p> <table border="0" data-bbox="873 909 1287 1045"> <thead> <tr> <th style="text-align: center;"><u>Model</u></th> <th style="text-align: center;"><u>Number of Zones</u></th> </tr> </thead> <tbody> <tr> <td style="text-align: center;">4281L</td> <td style="text-align: center;">Up to 4</td> </tr> <tr> <td style="text-align: center;">4281M</td> <td style="text-align: center;">Up to 8</td> </tr> <tr> <td style="text-align: center;">4281H</td> <td style="text-align: center;">Up to 16</td> </tr> </tbody> </table> <p>Zone number assignments (which are also transmitter ID assignments for 5700 RF system transmitters) can be in the 10-63 range, with the assigned zone number determining the zone type. A variety of RF system transmitters can be used to make up the wireless zones. This includes window/door units, smoke detectors, PIRs, and panic keys.</p> <p><i>Note:For brevity, subsequent references herein to the RF Receiver will be indicated by "4281" unless a specific model is named.</i></p>	<u>Model</u>	<u>Number of Zones</u>	4281L	Up to 4	4281M	Up to 8	4281H	Up to 16
<u>Model</u>	<u>Number of Zones</u>								
4281L	Up to 4								
4281M	Up to 8								
4281H	Up to 16								

Section 2. SYSTEM CONFIGURATIONS

ZONE RESPONSE TYPE DEFINITIONS

General Information

Each zone must be assigned to a zone type, which defines the way in which the system responds to faults in that zone. Zone types are defined below (*"Type 2" is not used in this system*).

Type 0

Zone Disabled
(or Undefined)

Program a zone with this zone type if the zone is not used.

Type 1

Entry/Exit Burglary

This zone type provides entry delay whenever the zone is faulted if the control is armed in the Away or Stay modes. When the panel is armed in the Instant or Maximum modes, no entry delay is provided. Exit delay begins whenever the control is armed, regardless of the arming mode selected. These delays are programmable. This zone type is usually assigned to sensors or contacts on doors through which primary entry and exit will take place.

Type 3

Perimeter Burglary

This zone type gives an instant alarm if the zone is faulted when the panel is armed in the Away, Stay, Instant or Maximum modes. This zone type is usually assigned to all sensors or contacts on exterior doors and windows.

Type 4

Interior, Follower

This zone type is active when the panel is armed in the Away or Maximum modes. Entry delay (using the programmed entry time) results if the panel is armed in the Away mode and the entry/exit zone is faulted first. Otherwise this zone type gives an instant alarm. *Exit* delay is present for *any* arming mode. This zone type is usually assigned to a zone covering an area such as a foyer, lobby, or hallway through which one must pass (upon entry, after faulting the entry/exit zone) to reach the keypad to disarm the system. Since this zone type is designed to provide an instant alarm if the entry/exit zone is not violated first, it will protect an area in the event an intruder hides on the premises prior to the system being armed, or gains access to the premises through an unprotected area. **This zone type is bypassed automatically when the panel is armed Stay or Instant .**

Type 5

Trouble by Day/
Alarm by Night

This zone type will give an instant alarm if faulted when armed in the Away, Stay, Instant or Maximum (night) modes. During the disarmed state (day), the system will provide a latched trouble sounding from the keypad (and a central station report, if desired). Usually assigned to a zone which contains a foil-protected door or window (such as in a store), or to a zone covering a "sensitive" area such as a stock room, drug supply room, etc. This zone type can also be used on a sensor or contact in an area where immediate notification of an entry is desired.

Type 6

24-hour Silent Alarm

This zone type sends a report to the Central Station but provides no keypad display or sounding. This zone type is usually assigned to a zone containing an Emergency button.

Type 7

24-hour Audible Alarm

This zone type sends a report to the Central Station, and provides a rapid beeping sound at the keypad, and an audible external alarm. This zone type is usually assigned to a zone that has an Emergency button.

Type 8

24-hour
Auxiliary Alarm

This zone type sends a report to Central Station and provides a rapid beeping sound at the keypad. **No bell output is provided.** Usually assigned to a zone containing a button for use in personal emergencies, or to a zone containing monitoring devices such as water or temperature sensors, etc.

Type 9

Supervised Fire

This zone type provides a fire alarm on short circuit and a trouble condition on open circuit. The bell output will pulse when this zone type is faulted. This zone type is always active and cannot be bypassed. **This zone type can be assigned to control panel wired zone 5, or certain wireless zones.**

Type 10

Interior w/Delay

This zone type gives *entry* delay (using the programmed entry time), if tripped when the panel is armed in the Away mode, regardless of whether or not an entry/exit delay zone was tripped first. This zone type is also active during Maximum mode, but *no* entry delay is provided (an alarm occurs immediately if the zone is tripped). *Exit* delay is present for *any* arming mode. **This zone type is bypassed automatically when the panel is armed Stay or Instant .**

By using a 4281 receiver and the appropriate 5700 series transmitters, all of the above zone types are available for the wireless portion of the system.

HARD-WIRED ZONES

Basic Control's Zones The FA120C supports 6 hard-wired zones, which are connected as zones 1-6. These zones must be EOLR supervised, and can use N.O. and/or N.C. sensors.

Zone Response Type	Any zone response can be assigned to devices on these zones except Supervised Fire (09), which can be assigned <i>only</i> to zone 5 (see below).
Response Time	300–500 msec. Zone 3 is optionally programmable for fast (10-15msec) response.
Max. Zone Resistance	300 ohms, excluding EOLR.
EOLR Supervised	<ul style="list-style-type: none"> • Supports both open circuit and closed circuit devices. • Connect open circuit devices in parallel across the loop. The 1,000 ohm EOLR must be connected across the loop wires at the last device. <p>Important: If the EOLR is not at the end of the loop, the zone is not properly supervised. The system may not respond to an open circuit within the zone.</p> <ul style="list-style-type: none"> • Connect closed circuit devices in series with the loop.
EOLR Fire Zone 5	<ul style="list-style-type: none"> • Of the 6 basic hard wired zones, only zone 5 can be used for fire. • Supports as many 4-wire smoke detectors as can be powered. • The zones must be configured for EOLR supervision. • The detectors must be wired in parallel, with the EOLR at the last detector for full supervision. • To supervise power, a supervisory module (e.g., System Sensor A7771601 EOL Relay Module) is required.

WIRED ZONE EXPANSION

No. 4219 Wired Expansion Unit If a No. 4219 Wired Expansion Unit is used, 8 wired EOLR zones can be added to the basic control's 6 wired zones, for a total of 14 (RF cannot be used if a 4219 is to be used).

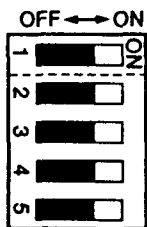

Location	Can be mounted within or outside of the control's cabinet (see page 9).
Connections	Connects to the control's remote keypad terminals.
Supervision	<ul style="list-style-type: none"> • Supervised against removal. • Has tamper protection for security when mounted outside of the cabinet.
Zone Information	<ul style="list-style-type: none"> • Eight wired expansion loops (designated A to H) may be assigned zone numbers 10-63 during programming, according to the desired zone type (see programming fields *76 to *83 plus *92). • RF may not be used in addition to a 4219, <i>even if some of the unit's wired expansion loops are not being used</i>.
Settings	The 4219's DIP switch must be set for a device address of "0" , as described in its instructions (bottom 4 switches to the RIGHT..."on"). Switch 1 determines zone A's response time ("ON" = normal response, "OFF" = fast response).

For additional information, see the instructions that accompany the 4219.

General

In addition to its basic 6 wired zones, the control, in conjunction with a 4281H RF Receiver, can provide up to 16 wireless zones [alternatively, with a 4281L up to 4 zones, or with a 4281M up to 8). Wireless keypads (5727, 5827BD) also can be used with the system.

The receiver can be mounted within the control's cabinet (see page 10) or installed remotely, in its own housing.

The 4281 recognizes alarms, status messages and keypad control messages from 5700 Series Wireless Transmitters operating at 345Mhz (315Mhz for Canadian version). These messages are processed and relayed to the control panel via a 4 wire connection to the control's remote keypad terminals. The 4281's RED, BLACK, YELLOW, and GREEN wires are connected in parallel with keypad wiring.

The 4281 can receive signals from wireless transmitters (listed below) within a nominal range (installed) of 200 feet.

The 4281's DIP switch must be set for a device address of "0", as described in the 4281's instructions (all switches to the RIGHT..."off").

Supervision

Each transmitter (except 5701, 5727, and 5827BD) is supervised by a check-in signal that is sent to the receiver at 70-90 minute intervals. If at least one check-in is not received from each *supervised* transmitter within a 12 hour period, the "missing" transmitter number(s) and "CHECK" will be displayed on the keypad.

Each transmitter (including 5701) is also supervised for low battery conditions and will transmit a low battery signal to the 4281, with the battery having at least 30 days of life remaining. If a 5727 or 5827BD transmits and has a low battery, it also will be indicated (as Zone 00 on a wired keypad).

Note: After a low or dead battery is replaced, activate the transmitter and then enter the security code + OFF to clear the system's memory of the "Low Battery" signal.

The 4281 itself is supervised. *If communication with the receiver is interrupted, or valid RF signals from at least one supervised wireless transmitter are not received within 12 hours, a tamper report (Zone 9) will be generated.*

House Identification

The 4281 responds only to transmitters set to the same House ID (01-31, see the DIP switch tables on page 32) as programmed in the control (see field *24). This prevents interference from transmitters in other nearby systems. To make sure that a House ID is chosen that is not in use nearby, conduct the House ID Sniffer Mode test described under *TESTING THE SYSTEM*.

Each transmitter's assigned zone number is DIP switch programmable in the unit as its transmitter ID (except wireless keypads, which are fixed at ID 00). Whenever a transmission takes place, whether for an alarm, fault, check-in, or low battery, the ID number is sent along with the message to the 4281 which, in turn, relays this information to the control, which displays the condition and zone number on the keypad.

Certain IDs in the assignment range of 10-63 have the following characteristics:

Transmitters set for IDs of 32-47 will have a 3 minute lock-out between transmissions to conserve battery life (normally PIR units, but transmitters protecting *frequently used* doors and windows should also be set for IDs in this range).

Transmitters set for IDs of 48-55 (FIRE) will transmit once every 12 seconds while the zone is faulted. **Transmitters set for IDs of 56-63** will transmit once every 3 seconds while faulted. These two ranges of zone numbers have high signal priority and their frequent transmissions while faulted insure retriggering of the alarm until the cause is removed.

Transmitter IDs of 62 and 63 are unsupervised to allow removal of the 5701 off-premises. Signal priority is higher than burglary.

WIRELESS TRANSMITTERS for the 4281 are described on page 31. **DIP SWITCH SETTING TABLES** are shown on page 32.

Transmitter Identification

5700 RF System Installation Advisories

1. If the 4281 Receiver is to be mounted remotely (not in the control's cabinet), place it in a high, centrally located area for best reception.
2. Do not locate receiver or transmitters on or near metal objects. This will decrease range and/or block transmissions.
3. Do not locate receiver in an area of high RF interference (revealed by frequent or prolonged lighting of the LED in the 4281 receiver...random flicker is ok).
4. Before mounting transmitters permanently, conduct Go/No Go Tests to verify adequate signal strength (see *TESTING THE SYSTEM*) and reorient or relocate transmitters if necessary.

Section 3. MOUNTING THE CONTROL, LOCK, & PC BOARD

Mounting the Cabinet

The FA120C is supplied with a 12-1/2" (318mm) wide x 14-1/2" (368mm) high x 3" (76mm) deep cabinet suitable for use in residential installations.

Mount the control cabinet to a sturdy wall using fasteners or anchors (not supplied) in a clean, dry area which is not readily accessible to the general public. 4 mounting holes are provided at the back of the cabinet.

Installing the Lock (if Used)

The cabinet can be closed and secured *without* a lock by using 2 screws in the cover's edge.

Use an Ademco No. N6277 Cam Lock and No. N6277-1 Push-On Clip (Retainer Clip).

1. Remove the cabinet cover. *It is easily removable for servicing and is easily reinstalled.*
2. Remove the lock knockout from the control cabinet cover. Insert the key into the lock. Position the key in the hole making certain that the latch will make contact with the latch bracket when the door is closed.
3. While holding the lock steady, insert the retainer clip into the retainer slots. Position clip as illustrated to facilitate easy removal.

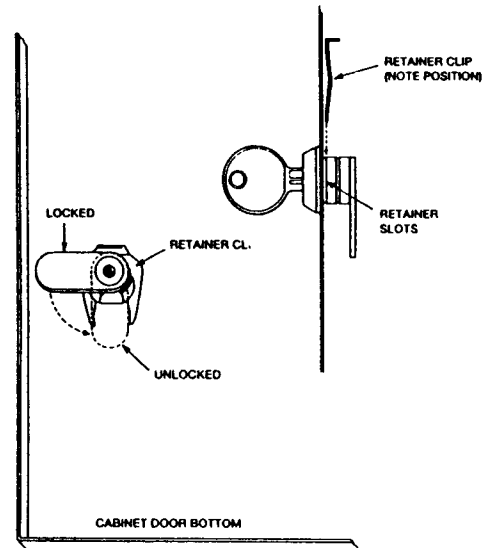

Installing the Control's Circuit Board Alone, or (if used), with a 4219

IMPORTANT!
Before installing the cabinet's contents, be sure to remove the appropriate metal cabinet knockouts.

DO NOT ATTEMPT TO REMOVE THE KNOCKOUTS AFTER THE CIRCUIT BOARD HAS BEEN INSTALLED.

Control's Circuit Board

1. Hang two long mounting clips (provided) on the raised cabinet tabs (see Detail B below).
2. Insert the top of the circuit board into the slots at the top of the cabinet. Make sure that the board rests on the correct row (see Detail A).
3. Swing the base of the board into the mounting clips and secure the board to the cabinet with the accompanying screws (see Detail B).

4219

1. Insert self-tapping screws (provided) in two adjacent raised cabinet tabs. Leave the heads projecting 1/8".
2. Hang the unit on the screw heads via two of the slotted holes at the rear of its housing, as shown.
3. The 4219's cover can be left off if the cover tamper jumper is placed in its upper (not tampered) position (see Detail C). The tampered cover is necessary for installations outside of the control's cabinet.

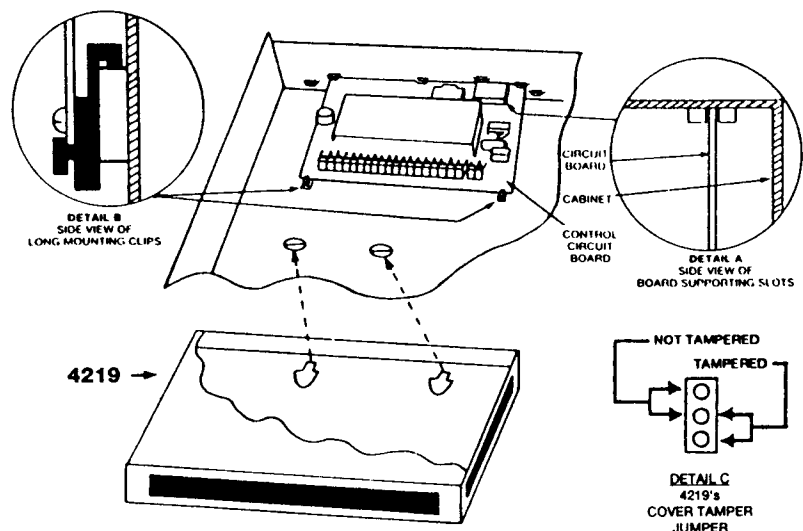

Installing Control and RF Receiver Circuit Boards Together, in the Same Cabinet

IMPORTANT!
 Before installing the cabinet's contents, be sure to remove the appropriate metal cabinet knockouts.
 DO NOT ATTEMPT TO REMOVE THE KNOCKOUTS AFTER THE CIRCUIT BOARDS HAVE BEEN INSTALLED.

1. Hang two *short* (black) mounting clips (provided with receiver) on the raised cabinet tabs, as shown in Detail B below.
2. Insert the top of the receiver board (removed from its own case as described in *its* instructions) into the slots at the top of the cabinet (see Detail A). Make sure that the board rests on the correct row of tabs.
3. Swing the base of the board into the mounting clips and secure it to the cabinet with the accompanying screws (see Detail B).
4. Insert the top of the control's board into the slot in the clips and position two *long* (red) clips at the lower edge of the board (see Detail C).
5. Swing this board into place and secure it with two additional screws.
6. Insert grounding lugs (supplied with the receiver) through the top of the cabinet into the *left-hand* terminals of the antenna blocks (at the upper edge of the receiver board) and secure them to the cabinet top with the screws provided, as shown in Detail D.
7. Insert the receiver's antennas through the top of the cabinet, into the blocks' *right-hand* terminals, and tighten the screws.

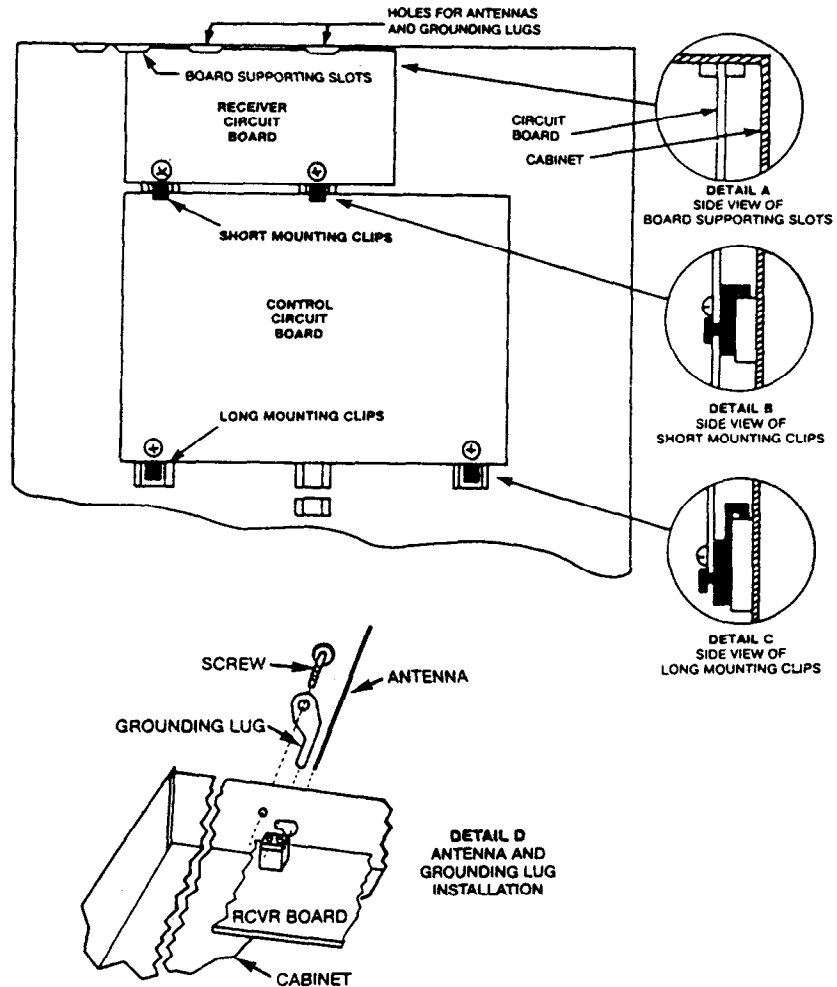

Section 4. WIRING & POWERING THE SYSTEM

(See Summary of Connections Diagram on Page 33)

IMPORTANT: Do not connect the battery, or plug in the AC transformer, until all other wiring connections have been completed.

Grounding the System

Terminal 21 is the earth ground connection point. In order for the protective devices in this product to be effective, the designated terminal must be terminated in a good earth ground. The following are examples of good earth grounds available at most installations:

Metal cold water pipe: Use a non-corrosive metal strap firmly secured to the pipe to which the lead is electrically connected and secured.

AC power outlet ground: Available from 3-prong, 120 VAC power outlets only. To test the integrity of the ground terminal, use a 3-wire circuit tester with neon lamp indicators, such as the UL Listed Ideal Model 61-035, or equivalent, available at most electrical supply stores.

Terminals and Connections

- 1 & 2: AC Input (16.5VAC, 25VA) from No. 1321/TF2 plug-in transformer (in U.S.A.). **Note** For Canadian installations, a No. 1321CN transformer must be used.
- 3: Alarm relay output(+), 12VDC, 2.0A maximum
Note: For UL installations, Alarm Sounder plus Auxiliary Power currents should not exceed 600mA total.
- 4: Ground (-) Return for Alarm Output Auxiliary Power and Wired Fire. Via BLACK lead for Keypad(s)† and 4281, 4219, or 4116.
- 5: +12VDC Output (at 500mA max.) for Auxiliary Power and Wired Fire. Via RED leads for Keypad(s)† and 4281, 4219, or 4116.
- 6: Data In from Keypad(s)† and 4281, 4219, or 4116, via GREEN leads.
- 7: Data Out to Keypad(s)† and 4281, 4219, or 4116, via YELLOW leads.
- 8: Zone 1. **Note:** (For each zone used, a 1,000 Ohm EOLR should be wired between the farthest sensor connected to the zone terminal and the low side of the zone.)
- 9: Zones 1 and 2 Return
- 10: Zone 2 (see Note at zone 1)
- 11: Zone 3 (see Note at zone 1)
- 12: Zones 3 and 4 Return
- 13: Zone 4 (see Note at zone 1)
- 14: Zone 5 (see Note at zone 1)
- 15: Zones 5 and 6 Return.
- 16: Zone 6 (see Note at zone 1)
- 17: Handset (TIP).
- 18: Handset (RING).
- 19: Incoming Phone Line (TIP).
- 20: Incoming Phone Line (RING).
- 21: EARTH GROUND (a proper earth ground must be provided to protect the system from lightning and electrostatic discharge damage).

Warning: To prevent the risk of electrical shock, disconnect the telephone line at the Telco jack before servicing the unit.

RED LEAD: Battery (+). When AC is present, 13.8VDC is being developed to recharge a gel lead acid battery and when AC is absent, 12VDC current is drawn from the battery. Battery lead reversal will blow the battery fuse.

BLACK LEAD: Battery (-).

† Up to 4 keypads may be used (check total auxiliary current, per SPECIFICATIONS). Each 5330 Keypad used *must* be on an individual home run. No more than 220' of #22 wire or 550' of #18 wire should be used for each run.

Addressable keypads (e.g., FA310KP, FA250KP) may be used, if they are set to their non-addressable mode (device ID 31).

Power-up Procedure

1. Make sure that the total current to be drawn from the Alarm Output terminals (3 & 4) and Auxiliary Power Output terminals (4 & 5) does not exceed the values indicated in the *SPECIFICATIONS* section and on the *SUMMARY OF CONNECTIONS* diagram.
2. Wire the transformer to the panel (before connecting the battery) as shown on the *SUMMARY OF CONNECTIONS* diagram. **Do not plug in at this time.**
3. Connect all loops, devices, keypads, etc. to the panel.
4. Plug the transformer into a 24 hour, uninterrupted AC outlet. After some initial displays (see page 17) and approximately one minute, the green POWER or READY LED on the keypad(s) should be lit and the display(s) should indicate that the system is ready to arm.
5. Connect the battery as shown in the *SUMMARY OF CONNECTIONS* diagram.

Section 5. SYSTEM OPERATION

SECURITY CODES

- Master Code** The installer programs the 4-digit Master Code initially as part of the programming procedure (see *PROGRAMMING THE SYSTEM*). The factory default Master code is "4110".
- The Master code can permit re-entry into the programming mode and also, in normal operation mode, is used to enter the user codes, which also allow access to the normal functions of the system.
- See the *PROGRAMMING* section for information on exiting the programming mode via fields *98 or *99.
- User Codes** In normal operation mode, the Master security code can be used to assign up to three secondary security codes. It can also be used to remove secondary codes from the system (individually).
- To assign (or change) a Secondary security code**, enter:
Master Code + [CODE key] + User # (2 or 3 or 4) + desired Secondary Code
The system will emit a single beep when each secondary code has been successfully entered.
- To delete a Secondary security code**, enter:
Master Code + [CODE key] + User # (2 or 3 or 4)
- Notes:**
- All Master and Secondary security codes permit access to the system for arming, disarming, etc.
 - If a secondary code is inadvertently repeated for different users, or one user's code is another's duress code (4th digit increased by 1), the lower user number will take priority.
 - Opening and closing reports are sent for the Master code as No. 1. User codes are sent as Nos. 2, 3, and 4 respectively.

KEYPAD FUNCTIONS

- General Information** Note that if QUICK ARM is enabled (field *21), the [#] key can be pressed instead of entering the security code, for any of the arming procedures (Away, Stay, Instant, Maximum, etc.). The security code is *always* required, however, when disarming the system.
- The keypad allows the user to arm and disarm the system, and perform other system functions, such as bypassing zones, and displaying zone descriptors. Zone and system conditions (alarm, trouble, bypass) are displayed in the Display Window.
- When an alarm occurs, keypad sounding and external sounding will occur, and the zone(s) in alarm will be displayed on the keypad. Pressing any key will silence the keypad sounder for 10 seconds. Disarming the system will silence both keypad and external sounders. When the system is disarmed, any zones that were in an alarm condition during the armed period will be displayed (memory of alarm). To clear this display, simply repeat the disarm sequence (enter the security code and press the OFF key).
- The keypads also feature chime annunciation, and 3 panic keys or key pairs. One is programmable for silent, audible, fire or personal emergency alarms. Two are fixed-function (one for silent and one for audible).
- The central station can be notified of an alarm condition, if that service is connected.

Arming Functions

The following is a brief list of system commands. For detailed information concerning system functions, refer to the User's Manual.

- Disarmed, Not Ready** Before arming, the system must be in the READY condition (all zones must be intact). If the "NOT READY" message appears, press the READY [*] key to display faulted zones.
- Arming Away** Enter code + AWAY [2].
- Arming Stay** Enter code + STAY [3].
- Arming Instant** Enter code + INSTANT [7].
- Arming Maximum** Enter code + MAXIMUM [4].
- Disarming** Enter code + OFF [1].
- Bypassing Zones** Enter code + BYPASS [6] + zone number(s).
- Forced (Quick) Bypass** (If enabled) To automatically bypass all faulted zones, use "Quick Bypass" method: Enter code + BYPASS (then stop).
- Chime Mode** Enter code + CHIME [9].
To turn chime mode off, enter code + CHIME again.

SUMMARY OF ARMING MODES

Mode	Features for Each Arming Mode			
	Exit Delay	Entry Delay	Perimeter Armed	Interior Armed
AWAY	Yes	Yes	Yes	Yes
STAY	Yes	Yes	Yes	No
INSTANT	Yes	No	Yes	No
MAXIMUM	Yes	No	Yes	Yes

Keyswitch Operation (if installed)

A single LED is used to indicate the status of the system:

LED OFF = Not Ready for Arming SLOW FLASH = Ready for Arming

- Arming Away** Turn key to right for 1/2 second.
- Arming Stay** Hold key turned to right for more than one second.
Keypads will beep twice (AWAY mode) or 3 times (STAY mode) and the keyswitch LED will flash rapidly.

Disarming Turn key to right.

If an alarm has occurred during the armed period, the keyswitch's LED will not flash upon disarming (thus indicating memory of the alarm). Turning the keyswitch key to the right a second time after disarming can clear the alarm from memory, but it is advisable, instead, to refer to a keypad to diagnose and clear any problem, and to subsequently clear alarm memory.

Panic Keys

IMPORTANT:
For the Panic functions to be of practical value, the system must be connected to a central station.

There are three panic key pairs and (on some keypads) lettered keys that, if programmed, can be used to manually initiate alarms and send a report to the central station.

The key(s) for zone 7 can be programmed for 24 Hour Silent, Audible, Personal or Fire Emergency response.

The key(s) for zones 95 and 96 have fixed-functions:

95 = Silent Panic, 96 = Audible Panic.

The panic function is activated when both keys of the appropriate key pair are pressed at the same time, or the appropriate lettered key is pressed for at least 2 seconds.

The panic functions are identified by the system as follows:

KEYS	Displayed as Zone	Function
[1 & *], or [A]	95	Silent Panic
[* & #], or [B]	07	Programmable
[3 & #], or [C]	96	Audible Panic

- Keys [A], [B], [C] are not on all keypads.
- Key [D], if present, is not active here.

Note: If [1 & *], or [A] is pressed after [3 & #], or [C], the initial display of zone 96 will be deleted from the keypad display, but the reports will go in properly (causing a silent alarm after an audible is not a likely scenario).

TROUBLE CONDITIONS

General Information

The word "CHECK" on the Keypad's display, accompanied by a rapid "beeping" at the Keypad, indicates that there is a trouble condition in the system. The audible warning sound can be silenced by pressing any key. Instruct users to call for service immediately upon seeing any of the following messages.

"Check" and "Battery" Displays

- A display of "CHECK" and one or more zone numbers indicates that a problem exists with the displayed zone(s) and requires attention.

When the problem has been corrected, the display can be cleared by entering the OFF sequence (code plus OFF key) twice.

- If there are wireless sensors in the system, the CHECK condition may also be caused by some change in the environment that prevents the receiver from hearing a particular sensor.
- A display of "BAT" with no zone number indicates that the system's main standby battery is weak.
- A display of "BAT" with a zone number and a once per minute "beeping" at the keypad indicates that a low battery condition exists in the wireless sensor displayed (zone "00" indicates a wireless keypad). If the battery is not replaced within 30 days, a CHECK display may occur.

Power Failure

- If there is no keypad display at all, and the POWER indicator (if present) is not lit, operating power for the system has stopped and the system is inoperative.
- If the message "NO AC" is displayed, and the POWER indicator (if present) is off, the keypad is operating on battery power only.
- If the battery standby capacity is used up during a prolonged AC power outage, the control's auxiliary power will shut down to minimize deep discharge of the battery.

Other Displays (Fixed Word Keypads)

- dI This may appear occasionally for a few seconds during normal system operation, but if this remains displayed for more than 1 minute, the system is disabled.
- CC The system is in communication with the central station for change of function or status verification.
- FC A communication failure has occurred.
- OC The keypad is not receiving signals from the control panel and sees an open circuit.

Section 6. PROGRAMMING THE SYSTEM

General Information

Installer options are stored in non-removable, electrically erasable, non-volatile EEROM memory. These options must be programmed for the particular installation to establish its specific alarm and reporting features.

Note: It is possible to program the system at any time, even at the installer's premises prior to the actual installation. Simply apply power temporarily to the control and then program the unit as desired.

**THE SECURITY CONTROL MAY BE PROGRAMMED
VIA AN FA200KP (FIXED ENGLISH) KEYPAD
OR A 5330 (ALPHA) KEYPAD.**

Note: An FA250KP or FA310KP (Addressable, FIXED ENGLISH) Keypad may be used, provided it is set to its non-addressable mode (device ID 31).

The initial sequence of entries should follow the order on the programming sheet.

When programming, the field number will be displayed on the keypad's display; also, each entry is displayed as it is keyed in. After programming, values that have been entered in each field can be reviewed and, if necessary, modified.

When programming from the keypad, note the following:

1. Enter the Programming mode by simultaneously depressing the [*] and [#] keys **within 50 seconds after power is applied to the Control**, or subsequently by keying the code 4 + 1 + 1 + 0 followed by depression of CODE + 0 keys. If a different Master code is subsequently programmed, use it instead of 4110 to gain access to the Programming mode. *If the Programming mode was exited previously using a *98, it will prevent entry into the Programming mode by the use of the Master Code + CODE + 0.*
2. Immediately following entry into the program mode, field *20 will be displayed. (If a 5330 keypad is used, 00 will be displayed. Enter *20 to access the programming start point.) Following the above display, the system is ready to accept entries for field *20.
3. To program a data field, key [*] plus **Field No.** (for example, *21), then make the required entry.
4. To simply review a data field, key [#] plus **Field No.** No changes will be accepted in this mode.
5. When a data field has been completely programmed, the keypad will normally "beep" three times and then automatically proceed to, and display, the next data field number to be programmed (if not, key [*] plus the **Field No.** of the next field to be programmed).
6. If the number of digits that you enter in the data field is less than the maximum permitted (for example, phone number), then the keypad will display the last data entered. To proceed, the next data field number to be programmed must then be entered (for example, *42).
7. If a field is improperly entered, the keypad will display **EE**. Simply re-enter [*] or [#] plus the field number.

**Summary of
Programming
Commands**

FUNCTION	PROCEDURE
ENTER PROGRAMMING MODE	1. POWER UP, then depress [*] and [#] both at once, within 50sec of powering up. OR 2. Initially, key: 4 + 1 + 1 + 0 plus CODE key + 0. OR 3. If different Master Code is programmed, key : MASTER CODE + CODE KEY + 0. (if *98 was used to exit previously, method 1 above must be used to enter the program mode again)
EXIT PROGRAMMING MODE	*99 allows re-entry to programming mode via type 2 or 3 entry method above. *98 inhibits re-entry to programming mode via type 2 or 3 entry method.
ADVANCE TO FIELD	[*] + Field No. (e.g., 21, 38, 55, etc.)
PROGRAM FIELD	[*] + Field No., followed by data entries.
ERASE FIELDS	[*] + Field No. + [*] (only applies to fields 40 thru 43 and 94).
READ FIELD	[#] + Field No.

Special Messages

OC = OPEN CIRCUIT (no communication between Keypad and Control).

EE = ERROR (program entry mistake). Re-enter the field number or data).

After powering up, **AC**, **dl** (disabled) and **NOT READY** will be displayed after approximately 4 seconds. This will revert to **READY** in appx. 1 minute, which allows PIRS, etc. to stabilize. To bypass this delay, press: [#] + [0].

If **E4** or **E8** appears, more zones than the expansion units can handle have been programmed. Correct the program and then completely de-power and re-power the control to clear this indication and remove the disable indication.

E4 = ERROR (using 4281L): If a 4281L is used instead of the 4281H and if anything is programmed in fields *80 to *91, the keypad will display **E4** and the control will be disabled, since the 4281L does not use those fields. Only 00/00 should appear in *80 to *91.

E8 = ERROR (using 4281M): If a 4281M is used instead of the 4281H and if anything is programmed in fields *84 to *91, the keypad will display **E8** and the control will be disabled, since the 4281M does not use those fields. Only 00/00 should appear in *84 to *91.

PROGRAMMING DATA FIELDS

THE CENTERFOLD PROGRAMMING FORM CAN BE USED TO RECORD THE DATA FOR THIS INSTALLATION

SYSTEM ARMING (*20-*28)

- *20 MASTER CODE**
Enter 4 digits, 0-9 (entry of all 4 is mandatory).
Use of a "9" in the last position inhibits the Ambush feature.
- *21 QUICK ARM ENABLE**
If enabled, [#] key can be used instead of security code when arming the system.
Enter 0 for disabled or 1 for enabled.
- *22 KEYSWITCH ENABLE**
Enter 0 for no or 1 for yes.
- *23 FORCED BYPASS FUNCTION**
All zones that are bypassed by this function will be displayed after the bypass is initiated.
0 = No forced bypass.
1 = Allows forced bypass of all open zones.
- *24 RF RECEIVER HOUSE ID CODE**
If 4281 type RF receiver used, enter 01-31 House ID.
With 4219, enter 90. Otherwise enter 00.
- *28 CONFIRMATION OF ARMING DING**
Enter 0 for no or 1 for yes.
If selected, ding is external sounder only and will occur at time of kissoff of closing report. If closing report is not programmed, ding will occur at end of exit time.

ZONE RESPONSE PROGRAMMING (*29-*39)

- *29 FIRE SOUNDER TIMEOUT DISABLE**
Enter 0 to enable the sounder timeout for fire or 1 to disable it.
- *30 ALARM BELL TIMEOUT**
External sounder will shut off after time allotted. Enter 1 digit.
0 = No timeout 2 = 8 minutes
1 = 4 minutes 3 = 12 minutes

ZONE TYPES FOR PROGRAMMING FIELDS *31-*37	
0 = Zone Disabled (or Undefined)	6 = 24 Hr (Silent)
1 = ENTRY/EXIT, Burglary	7 = 24 Hr (Audible)
2 = <i>not used</i>	8 = 24 Hr (Auxiliary)
3 = PERIMETER, Burglary	9 = FIRE (Fields *35 and *37 only)
4 = INTERIOR/FOLLOWER, Burglary	10 = INTERIOR w/DELAY, Burglary (To program, enter # + 10)
5 = TROUBLE BY DAY/ ALARM BY NIGHT, Burglary	

- *31 ZONE 1 RESPONSE TYPE**
Enter 1 digit from Zone Type Table above.
- *32 ZONE 2 RESPONSE TYPE**
Enter 1 digit from Zone Type Table above.
- *33 ZONE 3 RESPONSE TYPE**
Enter 1 digit from Zone Type Table above.
- *34 ZONE 4 RESPONSE TYPE**
Enter 1 digit from Zone Type Table above.
- *35 ZONE 5 RESPONSE TYPE**
Enter 1 digit from Zone Type Table above.
- *36 ZONE 6 RESPONSE TYPE**
Enter 1 digit from Zone Type Table above.
- *37 ZONE 7 RESPONSE TYPE (Keypad Panic, Key B or *&#)**
Enter 1 digit from Zone Type Table above.
Only zone types 0, 6, 7, 8, 9 are applicable

**DIALER
PROGRAMMING
(*40-*49)**

- *38 ENTRY DELAY**
System will wait the time allotted before sounding alarm upon entering.
0 = 0 sec. 2 = 30 sec.
1 = 20 sec. 3 = 45 sec. (EXIT delay = Entry delay plus 15 seconds)
- *39 ZONE 3 RESPONSE TIME TO OPEN**
0 = 400ms nominal 1 = 10ms nominal
- *40 PABX ACCESS CODE**
Enter 4 digits, 0-9, for each PABX digit needed to access an outside line. To skip this field, enter *. If * is entered, no PABX number will be dialed and nothing will appear in this field. End field by entering *41 if not filled. To clear entries from field, press *40*.
- *41 PRIMARY PHONE No.**
Enter up to 12 digits, 0-9. Do not fill unused spaces. End field by entering *42 if not filled. To clear entries from field, press *41*.
Note: Back-up reporting (8 calls are made to the secondary phone number if no kiss-off is received after 8 attempts to the primary number) is automatic only if there is a secondary phone number.
- *42 SECONDARY PHONE No.**
See field *41 entry info. and Note. End field by entering *43 if not filled. To clear entries from field, press *42*.
- *43 SUBSCRIBER ACCOUNT. No.**
Enter digits 0-9; #+11=B; #+12=C; #+13=D; #+14=E; or #+15=F. Enter * as the fourth digit if a 3 digit acct no. (for 3+1 dialer reporting format) is used. Enter 0 as the first digit of a 4-digit acct no. for nos. 0000-0999. End field by pressing * (and press next field) if only 3 digits are used. To clear entries from field, press *43*.
- *44 REPORT FORMAT**
Determine which format is to be used to report to the central station. Enter 1 digit.
0 = 3+1; 4+1 ADEMCO L/S Standard 6 = 4+2 ADEMCO Express
1 = 3+1; 4+1 Radionics Standard 7 = ADEMCO Contact ID Reporting
2 = 4+2 ADEMCO Lo Speed Standard 8 = 3+1; 4+1 ADEMCO Lo Speed Expanded
3 = 4+2 Radionics Standard 9 = 3+1; 4+1 Radionics Expanded
(Enter * as the 4th digit of *43, if 3+1 dialer reporting is to be used.)
For explanation of these formats, see page 23.
Note: The maximum number of communicator reports during one armed period is 10.
- *45 PHONE SYSTEM SELECT**
Enter 1 digit.
If Central Station Rcvr is *not* on WATS line:
0 = Pulse Dial 1 = Tone Dial
If Central Station Rcvr is on WATS line:
2 = Pulse Dial 3 = Tone Dial
- *46 SESCOA/RADIONICS SELECT**
0 = Radionics (0-9, B-F reporting)
1 = SESCOA (0-9 only reporting)
Select 0 for all other formats.
- *47 15 SECOND DIALER DELAY (BURGLARY)**
Allows time for subscriber to avoid a false alarm transmission.
Enter 0 for no or 1 for yes
- *48 24 HOUR TEST MESSAGE**
Enter 0 for no or 1 for yes.
If yes is selected, the Test Report Code entered in field *64 will be sent approximately 12 hours after local programming or uploading/downloading the program, and every 24 hours thereafter.
The report timing will not be offset appreciably by connection to the downloader unless uploading or downloading is done. Checking status, arming, etc. will affect the timing *only* to the extent of the connection time to the communicator.

***49 SPLIT/DUAL REPORTING**

Enter 0 to disable (Backup report only) or enter digit selected from the following table:

	To Primary Phone No.	To Secondary Phone No.
1 =	Alarms, Restore, Cancel	Others
2 =	All except Open/Close, Test	Open/Close, Test
3 =	Alarms, Restore, Cancel	All
4 =	All except Open/Close, Test	All
5 =	All	All

**ALARM
REPORT CODES
(*50-*59)**

***50 1ST DIGIT OF ZONE 95, ZONE 96 ALARM REPORT CODE (Keypad Panics: 95 = Key A or 1&*, 96 = Key C or 3&#)**

Enter the *first* digit of Zone 95's alarm report code in the left-hand box and 96's in the right-hand box. Select 1-9, 0, B, C, D, E, or F. Enter "#+10" for 0, "#+11" for B, "#+12" for C, "#+13" for D, "#+14" for E, "#+15" for F.

The *second* digit of each alarm report code (for 4 + 2 or expanded format) will be the same as that for zone 7 (as programmed in field *57).

For any format, if a "0" (not "#+10") is programmed for the first digit, no report is generated.

TO PROGRAM REPORT CODES FOR ALARM, SYSTEM STATUS, RESTORE, & TRANSMITTER IDs or 4219 ZONES (*51-*91)

With a 3+1 or 4+1 Standard Format: Enter a code in the *first* box: 1-9, 0, B, C, D, E, or F. Enter "#+10" for 0, "#+11" for B, "#+12" for C, "#+13" for D, "#+14" for E, "#+15" for F.

A "0" (not "#+10") in the *first* box will disable a report.

A "0" (not "#+10") in the *second* box will result in automatic advance to the next field when programming.

With an Expanded or 4+2 Format: Enter codes in *both* boxes (1st and 2nd digits) for 1-9, 0, or B-F, as described above.

A "0" (not "#+10") in the *second* box will eliminate the expanded message for that report.

A "0" (not "#+10") in *both* boxes will disable the report.

With Ademco Contact ID Reporting: Enter any digit (other than "0") in the *first* box, to enable zone to report. This is an "enabling" code only and is disregarded in the actual reporting to the central office. Entries in the *second* boxes will be ignored.

A "0" (not "#+10") in the *first* box will disable the report.

See examples on programming form.

***51 ZONE 1 ALARM REPORT CODE**

See box above.

***52 ZONE 2 ALARM REPORT CODE**

See box above.

***53 ZONE 3 ALARM REPORT CODE**

See box above.

***54 ZONE 4 ALARM REPORT CODE**

See box above.

***55 ZONE 5 ALARM REPORT CODE**

See box above.

***56 ZONE 6 ALARM REPORT CODE**

See box above.

***57 ZONE 7 ALARM REPORT CODE**

(Keypad Panic, Key B or * & #)

See box above, and field *50.

***58 ZONE 8 ALARM REPORT CODE**

(Duress)

See box above.

***59 ZONE 9 ALARM REPORT CODE**

(Tamper)

See box above.

**SYSTEM STATUS
REPORT CODES
(*60-*68)**

- *60 **TROUBLE REPORT CODE**
See box above *51.
- *61 **BYPASS REPORT CODE**
See box above *51.
- *62 **AC LOSS REPORT CODE**
See box above *51.
- *63 **LOW BAT REPORT CODE**
See box above *51.
- *64 **TEST REPORT CODE**
See box above *51.
- *65 **OPEN REPORT CODE**
See box above *51.
2nd digit = User #, if expanded or 4+2 reporting is selected.
- *66 **CLOSE REPORT CODE**
See box above *51.
2nd digit = User #, if expanded or 4+2 reporting is selected.
Report also sent for Arming STAY, if contact ID format is used.
- *67 **RF XMTR. LOW BATTERY REPORT CODE**
See box above *51.
- *68 **CANCEL REPORT CODE**
See box above *51.

**RESTORE
REPORT CODES
(*69-*75)**

- *69 **GROUP RESTORES FOR TROUBLE, RF LOW BATTERY, BYPASS**
Enter 0 for no (report for each restore)
or 1 for yes (report after all zones restored).
Note: "1" not applicable to Contact ID reporting.
- *70 **ALARM RESTORE REPORT CODE, 1ST DIGIT**
2nd digit is automatically sent as the 2nd digit of the zone alarm report code programmed in fields *51-*59 and *76-*91, if expanded or 4+2 reporting is selected.
- *71 **TROUBLE RESTORE REPORT CODE**
See box above *51. Trouble restore is reported only if all troubles in the system are restored, if yes has been selected for *69.
- *72 **BYPASS RESTORE REPORT CODE**
See box above *51.
- *73 **AC RESTORE REPORT CODE**
See box above *51.
- *74 **LOW BATTERY RESTORE REPORT CODE**
See box above *51.
- *75 **RF TRANSMITTER. LOW BATTERY RESTORE CODE**
See box above *51.

**RF TRANSMITTER IDs
or 4219 LOOP ZONES,
& REPORT CODES
(*76-*92)**

When Using	These Fields Can Be Used
4281L	*76-*79 plus *92
4281M	*76-*83 plus *92
4281H	*76-*92
4219	*76-*83 plus *92

RF XMTR ID or 4219 ZONE	ZONE TYPE	RF XMTR ID or 4219 ZONE	ZONE TYPE
10-13	ENTRY/EXIT, Burg.	48-55	FIRE
14-29	PERIMETER, Burg.	56-61	TROUBLE BY DAY/ ALARM BY NITE, Burg.
30-43	INT/FOLLOWER, Burg.	62	24 hr. (audible)
44, 45	INT w/DELAY, Burg.	63	Programmed by field *92
46, 47	PERIMETER, Burg.		

For *76 -*91 (where applicable), enter an appropriate two digit RF Xmtr ID or 4219 loop zone selected from the table above and a report code in accordance with the box above *51.

Note: *76-*92 can be used with 4281H .

- *76 1st RF TRANSMITTER ID or LOOP A ZONE/REPORT CODE
- *77 2nd RF TRANSMITTER ID or LOOP B ZONE/REPORT CODE

- *78 3rd RF TRANSMITTER ID or LOOP C ZONE/REPORT CODE
- *79 4th RF TRANSMITTER ID or LOOP D ZONE/REPORT CODE

Note: If a 4281L is used, *80-*91 do not apply.

- *80 5th RF TRANSMITTER ID or LOOP E ZONE/REPORT CODE
- *81 6th RF TRANSMITTER ID or LOOP F ZONE/REPORT CODE
- *82 7th RF TRANSMITTER ID or LOOP G ZONE/REPORT CODE
- *83 8th RF TRANSMITTER ID or LOOP H ZONE/REPORT CODE

Note: If a 4281M or 4219 is used, *84-*91 do not apply.

- *84 9th RF TRANSMITTER ID/REPORT CODE
- *85 10th RF TRANSMITTER ID/REPORT CODE
- *86 11th RF TRANSMITTER ID/REPORT CODE
- *87 12th RF TRANSMITTER ID/REPORT CODE
- *88 13th RF TRANSMITTER ID/REPORT CODE
- *89 14th RF TRANSMITTER ID/REPORT CODE
- *90 15th RF TRANSMITTER ID/REPORT CODE
- *91 16th RF TRANSMITTER ID/REPORT CODE

*92 ZONE RESPONSE OF XMTR ID 63 (if used)
Only zone types 0, 6, 7, 8, 9 are applicable (see table above *35).
Enter single digit.

**DOWNLOAD
INFORMATION
(*94, *95)**

*94 **DOWNLOAD PHONE NUMBER**
Enter up to 12 digits; 0-9. Do not fill unused spaces.
End field by entering *. To clear entries from field, press *94*.

*95 **RING DETECTION COUNT FOR DOWNLOADING**
Enter number of rings before control picks up phone line (or 0 or 15).
0 = disable station initiated download
1-14 = # of rings
15 = answering machine defeat

*96 **INITIALIZE DOWNLOAD ID AND SUBSCRIBER ACCT. No. FOR DOWNLOADING**
(No data entry required, loads defaults)

*97 **ZEROES ALL PROGRAM FIELDS**
(No data entry required)

Press *98 or *99 if exiting programming, or next Field No. if continuing.

**TO EXIT
PROGRAMMING MODE
(*98 or *99)**

*98 **EXITS PROGRAMMING MODE** and prevents re-entry by :
Master Code + CODE + 0

*99 **EXITS PROGRAMMING MODE** and allows re-entry by:
Master Code + CODE + 0
or by:
Power-up + * + #.

Section 7. SYSTEM COMMUNICATION

Report Code Formats

The Report Codes for Alarm, System Status, Restore, and RF XMTR IDs or 4219 zones shown in fields *50-*91 in the previous section can be designated in field *44 to report to the central station in any of the following formats:

The 3+1 and 4+1 Standard formats comprise a 3 (or 4) digit subscriber number and a single digit report code (e.g. Alarm, Trouble, Restore, Open, Close).

The 3+1 and 4+1 Expanded formats comprise a 3 (or 4) digit subscriber number, and a single digit report code, followed by a second line where the report code is repeated 3 (or 4) times and followed by another number (normally the zone number) or user ID related to that report.

The 4+2 formats comprise either a 4 digit subscriber number and two digit report code, or a 4 digit subscriber number and single digit report code, immediately followed by the zone number (normally) or user ID.

The Ademco Contact ID Reporting format (see next page) comprises a 4 digit subscriber number, 1 digit event qualifier ("new" or "restore"), 3 digit event code, 2 digit "00", and 3 digit zone, contact ID, user, or system status number .

Report	3+1/4+1 Standard	3+1/4+1 Expanded	4+2
Alarm	SSS(S) A	SSS(S) A AAA(A) Z	SSSS AZ
Trouble	SSS(S) T	SSS(S) T TTT(T) t	SSSS Tt
Bypass	SSS(S) B	SSS(S) B BBB(B) b	SSSS Bb
AC Loss	SSS(S) E	SSS(S) E EEE(E) A _C	SSSS EA _C
Low Batt	SSS(S) L	SSS(S) L LLL(L) L _B	SSSS LL _B
Open	SSS(S) O	SSS(S) O OOO(O) U	SSSS OU
Close	SSS(S) C	SSS(S) C CCC(C) U	SSSS CU
Test	SSS(S) G	SSS(S) G GGG(G)g	SSSS Gg
Restore	SSS(S) R	SSS(S) R RRR(R) Z	SSSS RZ
Alarm AC Restore	SSS(S) R _A	SSS(S) R _A R _A R _A R _A (R _A)A _C	SSSSR _A A _C
LoBat Res.	SSS(S) R _L	SSS(S) R _L R _L R _L R _L (R _L)L _B	SSSS R _L L _B
Trouble Res.	SSS(S) R _T	SSS(S) R _T R _T R _T R _T (R _T)t	SSSS R _T t
Bypass Res.	SSS(S) R _B	SSS(S) R _B R _B R _B R _B (R _B)b	SSSS R _B b

Where:

SSS or

SSSS = Subscriber ID

A = Alarm Code-1st digit

Z = Typically Zone Number**-2nd digit

Tt = Trouble Code (1st & 2nd digits)

Bb = Bypass Code (1st & 2nd digits)

EA_C = AC Loss Code (1st & 2nd digits)

LL_B = Low Battery Code(1st & 2nd digits)

O = Open Code-1st Digit

C = Close Code-1st Digit

U = User Number (1st & 2nd digits)

Gg = Test Code (1st & 2nd digits)

R = Restore Code (Alarm)1st & 2nd digits

R_Tt = Restore Code (Trbl)1st & 2nd digits

R_Bb = Restore Code (Byps)1st & 2nd digits

R_AA_C = Restore Code (AC)1st & 2nd digits

R_LL_B = Restore Code (Bat)1st & 2nd digits

**Zone number for: [* & #] or [B] = 7

Duress = 8

Tamper = 9

[1 & *] or [A] = 95

[3 & #] or [C] = 96

Ademco Contact ID Reporting takes the following format:

CCCC Q EEE GG ZZZ

where: CCCC = Customer (subscriber) ID

Q = Event qualifier, where:

E = new event, and R = restore

EEE = Event code (3 hexadecimal digits)

Note: For a complete list of event codes, refer to the central office receiver manual.

GG = Always 00.

ZZZ = Zone/contact ID number reporting the alarm, or user number for open/close reports. System status messages (AC Loss, Walk Test, etc.) contain zeroes in the ZZZ location.

Section 8. REMOTE PROGRAMMING AND CONTROL (DOWNLOADING)

General Information

The FA120C can be remotely programmed from an IBM compatible Personal Computer (PC), a Hayes Modem, and First Alert's FADL Software (as specified below).

Programming the control from a remote location is protected against compromise by someone attempting to defeat the system, using multi-levels of security protection:

1. **Security Code Handshake:** An 8-digit download ID code must be matched between the control and the downloader.
2. **Site Initiated Remote Programming:** The installer or subscriber initiates the callback from the subscriber premises (by pressing MASTER CODE + # + 1) while disarmed. All parameters can then be downloaded via the phone lines using a personal computer.
3. **Station Initiated Remote Programming:** The operator calls the site from your office to initiate the download call. The control hangs up and then calls back the PC via the preprogrammed telephone number. The unit can then be uploaded, downloaded, or controlled from your office.
4. **Data Encryption:** Data passed between the PC and the control is encrypted for security so that it is very difficult for a foreign device tapped into the phone line to take over communication and substitute system compromising information.

Equipment Required

At the premises:

- FA120C and keypad.

At the installer's office:

- An IBM PC compatible computer.
- *Either* a Hayes brand Smartmodem 1200 [Level 1.2 or higher external or Level 1.1 or higher (with 4 position DIP switch) internal style],
or a Hayes brand Optima 24 Plus FAX96 Modem.
- An FADL Downloading Software Diskette (Rev. 2.26, or higher).
- Appropriate interconnecting cables.

Programming

The downloading system can perform many functions when in communication with the control unit. Besides uploading and downloading, the status of the system can be observed and various commands can be initiated, as follows:

- Arm the System in the Away Mode; Disarm the System.
- Bypass a Zone.
- Force the System to Accept a New Program Download.
- Shut Down Communication (dialer) Functions (non-payment of monitoring fees in an owned system).
- Shut Down all Security System Functions (non-payment for a leased system).
- Inhibit Local Keypad Programming (prevents account takeover).
- Command the System to Upload a Copy of its Resident Program to the office.
- Read: Arming Status, AC Power Status, Lists of Faulted Zones, Bypassed Zones, Zones Currently in Alarm, Zones Currently in Trouble, and RF Sensors with Low Battery Conditions.

Notes: After the control and the PC have established valid communication, each keypad on the system will become inactive and will display "CC". The control, however, will still be scanning its zones and looking for alarms. If an alarm does occur, after communication is broken off, alarms are sounded and the proper dialer reports are sent to the central station. The keypads will become active after the download communication is terminated. The detailed operation of the download functions is covered in the installation instructions for the FADL Downloading Software Diskette.

**Remote Programming
Advisory Notes**

- Alarm and trouble reporting will be delayed during the time that the system and the Downloader are linked to each other following a valid exchange of codes, but the proper message will get through to the Central Station after the link is broken.
- Keypad entries are ignored during the time interval stated above.
- A copy of the program downloaded may be produced from the IBM PC compatible computer, using the product's internal report generator, when an optional printer is connected (consult your PC manual for proper printer and connections).
- Program Upload or Download Time: 45 seconds.
- The Firmware Revision Level now reported to the downloader is .02.

Section 9. TESTING THE SYSTEM

Procedure After installation is completed, the Security System should be carefully tested.

1. With the System in the disarmed state, check that all zones are intact. If **NOT READY** is displayed, press the [*] key to display the faulted zone(s). Restore faulted zone(s) if necessary, so that **READY** is displayed. Fault and restore every sensor individually to assure that it is being monitored by the system.
2. Enter the **security code** and press the **TEST** key. The outside sounder (if used) will sound for 1 second and then turn off each time a zone is faulted. A test report should be transmitted (if programmed) to the Central Station immediately. If the backup battery is discharged or missing, the sounder may not turn on and a **LOW BATTERY** report will be transmitted instead of a **TEST** report. The keypad will beep once per minute as a reminder that the system is in the Test Mode. To turn off the test mode enter the **security code** and press the **OFF** key.

Alarm messages will be sent to the central station during the following tests 3 and 4. Notify them in advance that tests will be in progress.

3. Arm the system and fault one or more zones. After 15 seconds (if optional dialer delay is selected), silence alarm sounder(s) by entering the **code** and pressing **OFF**. Check Entry/Exit delay zones.
4. Check the keypad-initiated alarms that are in the system by pressing the Panic key(s) for:
Zone 7: [* & #] or [B], Zone 95: [1 & *] or [A], or Zone 96: [3 & #] or [C]
For audible emergency (zone 96, or, if so-programmed, zone 7), the keypad will emit a steady alarm sound, and **ALARM and zone number** will be displayed. Silence the alarm by entering the **security code** and pressing **OFF**.
For silent emergency (zone 95, or, if so-programmed, zone 7), there will be no audible alarms or displays, but a report will be sent to the central station. Reset the zone by entering the **security code** and pressing **OFF**.
5. Notify the central station when all tests are finished, and verify results with them.
6. To test the wireless part of the system and the RF Receiver, 3 additional test modes are available:
 - a. **GO/NO GO TEST MODE**: By pressing **Master code + # + 4**, a mode similar to the user test mode (code + TEST) is entered, but the wireless receiver gain is reduced. Checking in this mode is critical in determining good mounting locations for the transmitters when the system is being installed and verifies that the RF transmission has sufficient signal amplitude margin for the installed system. Exit the mode by entering **Master code + OFF**.
 - b. **HOUSE ID SNIFFER MODE** : By pressing **Master code + # + 2**, a house code "sniffer" mode is enabled. The keypad will display the house code of any RF transmission it receives. In this way, you can check that you are not using the same house code as any nearby system (suggested test period: approx. 2 hrs). This mode can be exited by keying the **Master code + OFF**.
 - c. **TRANSMITTER SNIFFER MODE**: Pressing **Master code + # + 3** initiates a procedure to check that all transmitters have been properly programmed. The keypad will display all zone numbers of wireless units programmed into the system. As the system receives a signal from each of the transmitters, the zone number of that transmitter will disappear from the display. The transmitter codes may be checked upon installation, or in an installed system. All the wireless addresses should disappear after about 1-1/2 hours. This mode can be exited by keying **Master code + OFF**.

TROUBLESHOOTING GUIDE

S Y S T E M		
SYMPTOM	POSSIBLE CAUSE	REMEDY
1. Transmitted signal not received at 4281.	1a. Transmitter or 4281 not properly powered. 1b. Transmitter and 4281 not set to same house code. 1c. Transmitter located too far from 4281. 1d. Strong local RF interference (frequent or prolonged lighting of indicator LED on 4281 circuit board....occasional random flicker is ok). 1e. Metal shielding between transmitter and 4281. 1f. Transmitter malfunctioning. 1g. 4281 malfunctioning. 1h. Transmitter number (zone) not programmed.	1a. Check or change transmitter's battery. Check FA120C's AC power. 1b. Check code switches inside transmitter. Must match with RF House Code programmed in FA120C . 1c. Move transmitter or 4281. 1d. Relocate 4281. 1e. Check for large metal obstructions, then relocate transmitter if necessary. 1f. Verify by activating 4281 with another, similar transmitter. If O.K.now, return defective transmitter. 1g. Verify by making sure other transmitters cannot activate 4281. If defective, replace and return original 4281. 1h. Verify programming.
2. Transmitter zone number appears during Transmitter Sniffer mode, but does not clear.	2a. Transmitter battery not installed. 2b. 5700 System transmitter's DIP switch not set properly (house ID and transmitter ID).	2a. Install proper battery. 2b. Check and set the DIP switch.
3. Low Battery message on keypad.	3a. "Bat" alone. 3b. "Bat" + "00". 3c. "Bat" + "nn".	3a. System battery is low or missing. 3b. Remote RF keypad battery is low. 3c. Transmitter for zone nn has a low battery.
4. Periodic beep(s) from keypad.	4a. System is in TEST mode. 4b. A transmitter low battery has occurred and is displayed. 4c. A supervision CHECK has occurred.	4a. Enter "Code" + OFF to exit TEST mode. 4b. Enter "Code" + OFF and replace the battery. 4c. Check the transmitter indicated. Restore communication to the receiver to cancel the condition.
5. Nuisance or phantom alarm.	5a. Sensors not properly installed, wired, or monitored. 5b. Nearby neighbor has 5700 system (4281) with same house code. 5c. Universal transmitter (5715) programmed wrong.	5a. Check installation to see if in accordance with established procedure. 5b. Check with central monitoring station for neighbors with systems. Range can be 300 feet. Change house code if necessary. 5c. Check programming switches on transmitter.
6. Intrusion alarm for no apparent reason.	6a. Protected door or window opened while system armed. 6b. Improper user operation of exit/entry delays. 6c. Magnets located too far from switches, and/or doors and windows not properly aligned. 6d. Magnetic contacts improperly connected or wire broken. 6e. Entry door programmed as "instant". 6f. Loose fitting door or window being rattled by wind or vibrations.	6a. Check with all occupants of protected home. 6b. Check setting of entry delay . Exit delay is 15 seconds longer than the entry delay time. Remind user of same. 6c. Check all openings for proper switch and magnet orientation. 6d. Check wiring connections. Be sure wires are properly stripped and tightly fastened to screw terminals. 6e. Check and revise program. Reprogram transmitter number. 6f. Mount magnet closer to contact.
7. Repeated low battery signal.	7a. Transmitter located where temperature drops below 32° F. 7b. Poor quality or unspecified battery in transmitter. 7c. Transmitter malfunctioning.	7a. Change location. Use magnetic contacts to protect opening. 7b. Check battery. Use only 9V Duracell MN1604 or equivalent. 7c. Replace faulty transmitter.

(continued)

TROUBLESHOOTING GUIDE (continued)

C O N T R O L		
SYMPTOM	POSSIBLE CAUSE	REMEDY
1. "AC POWER" light off or "NO AC" displayed.	1a. Interrupted AC power supply.	1a. Check transformer connection and power line circuit breaker.
2. Digital communicator message not being received.	2a. FA120C in TEST mode. 2b. Telephone connection not secure. 2c. Telephone number in program needs prefix or access code. 2d. Telephone call to central monitoring station requires operator assistance. 2e. Digital communicator malfunctioning.	2a. Remove from TEST mode. 2b. Check all connections. 2c. Program prefix or access code into FA120C. 2d. FA120C system cannot work in this situation. 2e. Check with a different FA120C
3. Does not arm properly.	3a. Ready light not on.	3a. Try Bypass arming.
4. FA120C doesn't respond to keystrokes on keypad.	4a. "CC" displayed. 4b. "dl" displayed. 4c. "E4" or "E8" displayed.	4a. System is in communication with downloader at central station. Wait until download session is finished. 4b. System has just been powered and is in its one minute initialization. To bypass this time, press '#' + '0'. 4c. More zones have been programmed than the zone expansion modules can handle. Delete some zones or use a higher capability RF receiver.

S M O K E D E T E C T O R		
SYMPTOM	POSSIBLE CAUSE	REMEDY
1. Detector alarms, no apparent reason.	1a. Dust, dirt in sensing chamber. 1b. Improper location. 1c. Unit malfunctioning.	1a. Clean unit's sensing chamber with vacuum cleaner per unit's instructions. 1b. See unit's instructions for locations to avoid. Relocate as necessary. 1c. Replace detector.
2. Detector's siren sounds.	2a. Unit not receiving required power. 2b. Unit malfunctioning.	2a. Check for proper installation of battery. Try new battery. 2b. Replace detector.

Section 10. SPECIFICATIONS AND ACCESSORIES

SPECIFICATIONS

FA120C SECURITY CONTROL

1. **Physical:** 12-1/2" W x 14-1/2" H x 3" D (318mm x 368mm x 76mm)
2. **Electrical:**
 VOLTAGE INPUT: 16.5VAC from plug-in 25VA transformer,
 No. 1321/TF2 (in U.S.A.)
Note: For Canadian installations, a No. 1321CN transformer must be used.
 RECHARGEABLE BACK-UP BATTERY: 12VDC, 4AH (Gel type),
 Charging Voltage: 13.8VDC.
 ALARM SOUNDER: 12V, 2.0Amp output can drive 12V BELLS or can drive one
 or two 702 (**series** connected) self-contained 20-watt sirens. Do **not**
 connect two 702s in parallel.
 AUXILIARY POWER OUTPUT: 12VDC, 500mA max. Interrupts for smoke
 detector reset.
Note: For UL installations, Alarm Sounder plus Auxiliary Power currents should
 not exceed 600mA total.
 STANDBY TIME: 5 HRS with Auxiliary load of 500mA (using 4AH battery). To
 determine total standby battery load, add 100mA to total Aux. power output
 and remote keypad currents.
 FUSES: Battery (3A) No. 90-12, Sounder (2A) No. 90-2

3. Communication:

FORMATS SUPPORTED:

Ademco Express,

10 characters/sec, DTMF (TouchTone) Data Tones, 1400/2300Hz ACK,
 1400Hz KISSOFF.

Ademco Contact ID Reporting,

10 characters/sec., DTMF (TouchTone) Data Tones, 1400/2300Hz ACK,
 1400Hz KISSOFF.

Ademco Low Speed, 10 pulses/sec, 1900Hz Data Tone,
 1400Hz ACK/KISSOFF.

Radionics/SESCOA, 20 pulses/sec, 1800Hz Data Tone, 2300Hz
 ACK/KISSOFF.

Can report 0-9, B-F

Line Seize: Double Pole

Ringer Equivalence: 0.7B

FCC Registration No.: AC 398U-68192-AL-E

FA200KP REMOTE KEYPAD

1. **Physical:** 5-5/8" W x 4-11/16" H x 7/8" D (143mm x 119mm x 22mm)
2. **Electrical:** Voltage Input: 12VDC, Current Drain: 20mA
3. **Interface Wiring:**
 RED: 12VDC input (+) aux pwr GREEN: Data Out to Control
 YELLOW: Data In from Control BLACK: Ground

FA250KP REMOTE KEYPAD

1. **Physical:** 5-1/16" W x 6-3/8" H x 1-3/4" D (129mm x 162mm x 45mm)
2. **Electrical:** Voltage Input: 12VDC, Current Drain: 85mA
3. **Interface Wiring:**
 RED: 12VDC input (+) aux pwr GREEN: Data Out to Control
 YELLOW: Data In from Control BLACK: Ground

FA310KP REMOTE KEYPAD

1. **Physical:** 8.4" W x 4.75" H x 1.1" D (213mm x 121mm x 28mm)
2. **Electrical:** Voltage Input: 12VDC, Current Drain: 60mA
3. **Interface Wiring:**
 RED: 12VDC input (+) aux pwr
 BLUE: 18VDC input from optional No. 1350 or 1360 Power Pack
 (not usable on UL installations)
 GREEN: Data Out to Control
 YELLOW: Data In from Control
 BLACK: Ground and (-) connection
 from optional No. 1350 or 1360 Power Pack

**5330
REMOTE ALPHA
KEYPAD**

(Select Vector Device)

1. **Physical:** 7-3/4" W x 4-7/16" H x 1-1/4" D (197mm x 113mm x 32mm)
2. **Electrical:** Voltage Input: 12VDC, Current Drain: 105mA
3. **Interface Wiring:**
RED: 12VDC input (+) aux pwr GREEN: Data Out to Control
YELLOW: Data In from Control BLACK: Ground

**4281L, 4281M, 4281H
RF RECEIVERS
(5700 System)**

1. **Physical:** 7-3/8" W x 4-3/8" H † x 1-7/16" D (188mm x 112mm x 37mm)
† Including antenna: 10-7/8" H (277mm)
2. **Electrical:** Voltage Input: 12VDC
(from control's remote keypad connection points)
Current Drain: 35mA
3. **Interface Wiring:**
RED: 12VDC input (+) aux pwr GREEN: Data Out to Control
YELLOW: Data In from Control BLACK: Ground
4. **Range:** 200ft (60m) nominal indoors from wireless transmitters (the actual range to be determined with system in TEST mode).
5. **Zones:** With the FA120C: 4281L: accepts up to 4 transmitters
4281M: accepts up to 8 transmitters
4281H: accepts up to 16 transmitters

**4219
WIRED EXPANSION
UNIT**

1. **Physical:** 6-1/2" W x 4-1/4" H x 1-1/4" D (169mm x 108mm x 32mm)
2. **Electrical:** Voltage Input: 12VDC
(from control's remote keypad connection points)
Current Drain: 35mA
3. **Interface Wiring:**
RED: 12VDC input (+) aux pwr GREEN: Data Out to Control
YELLOW: Data In from Control BLACK: Ground
4. **8 EOLR Loops (A-H):** Loop A can be set for fast (10-15msec) response to an open.

**5800TM
TRANSMITTER
MODULE
used with
5827BD
Wireless
Bidirectional Keypad**

1. **Physical:** 2-1/4" W x 4-1/8" H x 7/8" D (57mm x 105mm x 22mm)
2. **Electrical:** Voltage Input: 12VDC
(from control's remote keypad connection points)
Current Drain: 20mA
3. **Interface Wiring:**
RED: 12VDC input (+) aux pwr GREEN: Data Out to Control
YELLOW: Data In from Control BLACK: Ground

ACCESSORIES (COMPATIBLE DEVICES)

- | Accessories | No. | Description |
|-------------|-----------------------|--|
| | 1321/TF2 | 16.5VAC, 25VA Plug-In Transformer (in U.S.A.) |
| | 1321CN | 16.5VAC, 25VA Plug-in Transformer (in Canada) |
| | 702 | Self-contained 20 watt Siren (indoor or outdoor). |
| | 740 | Extremely loud Piezoelectric Alarm Sounder, 122dB output (indoor or outdoor). |
| | 4116 | Tampered Single LED Remote Station (Arming/Disarming Keyswitch).
Note: Obtain Lockswitch separately (Ademco No. 2174-70, 4073-70, or 4005-70). |
| | 5716BR | Brown Cases and Mounting Brackets (3) for 5716, 5716WM. |
| | 5799 | Pkg. of 8 Magnets for 5716 |
| | System Sensor: | |
| | PA400B | Piezoelectric Alarm Sounder, 90dB output (mounts in single-gang box). |
| | 1412 | 4-wire Ionization Products of Combustion Detector |
| | 2412 | 4-wire Photoelectric Smoke Detector |
| | 2412TH | 4-wire Photoelectric Smoke Detector w/135°F (57°C) Heat Detector |
| | A7771601 | EOL Relay Module (Supervisory Module for wired fire zone) |

**5700 RF System
Wireless Transmitters
for
4281**

5701 Panic Transmitter

Programmable for either silent or audible 24 hour alarm (can be DIP switch programmed for zones 62 or 63).

5706 & 5707 Wireless Photoelectric Smoke Detectors

One piece smoke detectors with built-in transmitter (DIP switch programmable for zones 48-55). Built-in UL Listed 85 dB piezoelectric alarm sounder and audible low battery warning.

5711 Slimline Door/Window Transmitter

Can be used with any closed circuit sensor.

**5711WM Slimline Door/Window Transmitter
w/Reed Switch**

Magnet included for built-in reed switch. Can also be used with any closed circuit sensor.

**5715WH (White) or 5715BR (Brown)
Universal Transmitter**

DIP switch selectable for fast response, open or closed sensor usage, and has a tamper protected cover. Use in applications where open circuit heat detectors are needed or where fast response devices are employed.

**5716 Small Door/Window Transmitter
5716WM Small Door/Window Xmtr w/Magnet**

Can be used with any open or closed circuit sensor (DIP switch selectable). Features a built-in reed switch.

5742 Audio Glass Break Sensor/Transmitter

For use in unoccupied areas to detect the sound of shattering glass when a window is broken. Built-in 5716 type transmitter.

**5743 Dual Technology
Glass Break Sensor/Transmitter**

Detects the sound *and* shock vibrations of breaking glass and requires the presence of *both* to initiate an alarm condition transmission. Built-in 5716 type transmitter.

5775 PIR Detector/Transmitter

Dual element passive infrared detector/transmitter with built-in selectable pulse count. DIP switch programmable for zones 32-47. *Note:* There is a 3 minute lock-out between transmissions to conserve battery life.

Two interchangeable battery compartments are provided. One accommodates a single battery, and the other, two batteries. Use of the two-battery compartment can double the time between battery replacement..

5727 Wireless Keypad

Can be used to turn the burglary protection on and off, and features the same built-in panic functions as wired keypads for either silent or audible 24 hour alarm. An LED indication lights each time a key is pressed, to verify transmission. The keypad is identified as zone "00" (on wired keypads) when it transmits with a low battery.

**5827BD Wireless Bidirectional Keypad
(used with 5800TM Transmitter Module)**

Can operate the system similarly to wired keypads and can indicate system status via its 3 LEDs and sounder. Includes 3 panic keys for 24 hour silent or audible alarm. Requires a 5800TM Transmitter Module, to operate in conjunction with system's 4281 receiver. Key programmed, *has no DIP switch*. The keypad is identified as zone "00" (on wired keypads) when it transmits with a low battery.

TO THE INSTALLER

Regular maintenance and inspection (at least annually) by the installer and frequent testing by the user are vital to continuous satisfactory operation of any alarm system.

The installer should assume the responsibility of developing and offering a regular maintenance program to the user as well as acquainting the user with the proper operation and limitations of the alarm system and its component parts. Recommendations must be included for a specific program of frequent testing (at least weekly) to insure the system's proper operation at all times.

DIP SWITCH TABLES FOR WIRELESS DEVICES

House ID Switch Setting for All Devices Except 5716

HOUSE ID	DIP SWITCH SETTINGS				
HOUSE ID	1	2	3	4	5
1	UP	UP	UP	UP	dn
2	UP	UP	UP	dn	UP
3	UP	UP	UP	dn	dn
4	UP	UP	dn	UP	UP
5	UP	UP	dn	UP	dn
6	UP	UP	dn	dn	UP
7	UP	UP	dn	dn	dn
8	UP	dn	UP	UP	UP
9	UP	dn	UP	UP	dn
10	UP	dn	UP	dn	UP
11	UP	dn	UP	dn	dn
12	UP	dn	dn	UP	UP
13	UP	dn	dn	UP	dn
14	UP	dn	dn	dn	UP
15	UP	dn	dn	dn	dn
16	dn	UP	UP	UP	UP
17	dn	UP	UP	UP	dn
18	dn	UP	UP	dn	UP
19	dn	UP	UP	dn	dn
20	dn	UP	dn	UP	UP
21	dn	UP	dn	UP	dn
22	dn	UP	dn	dn	UP
23	dn	UP	dn	dn	dn
24	dn	dn	UP	UP	UP
25	dn	dn	UP	UP	dn
26	dn	dn	UP	dn	UP
27	dn	dn	UP	dn	dn
28	dn	dn	dn	UP	UP
29	dn	dn	dn	UP	dn
30	dn	dn	dn	dn	UP
31	dn	dn	dn	dn	dn

BIT VALUE: 16 8 4 2 1

5701 Panic Xmtr.

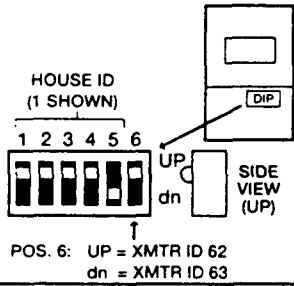

5727 Keypad

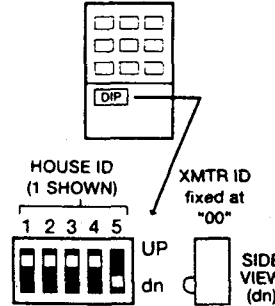

5706/5707 Smoke Detector Transmitter

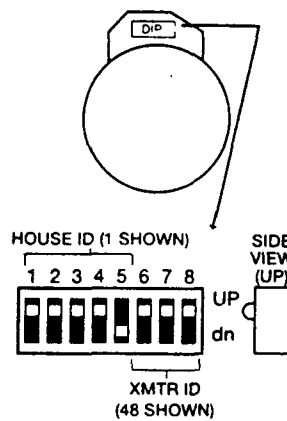

XMTR ID	DIP SWITCH SETTINGS		
XMTR ID	6	7	8
48	UP	UP	UP
49	UP	UP	dn
50	UP	dn	UP
51	UP	dn	dn
52	dn	UP	UP
53	dn	UP	dn
54	dn	dn	UP
55	dn	dn	dn

5775 PIR Detector/Transmitter

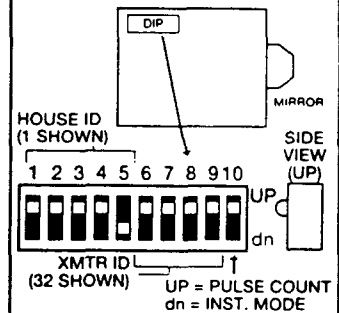

XMTR ID	DIP SWITCH SETTINGS			
XMTR ID	6	7	8	9
32	UP	UP	UP	UP
33	UP	UP	UP	dn
34	UP	UP	dn	UP
35	UP	UP	dn	dn
36	UP	dn	UP	UP
37	UP	dn	UP	dn
38	UP	dn	dn	UP
39	UP	dn	dn	dn
40	dn	UP	UP	UP
41	dn	UP	UP	dn
42	dn	UP	dn	UP
43	dn	UP	dn	dn
44	dn	dn	UP	UP
45	dn	dn	UP	dn
46	dn	dn	dn	UP
47	dn	dn	dn	dn

5715 Universal Xmtr.

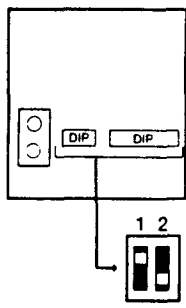

XMTR ID	DIP SWITCH SETTINGS					
XMTR ID	6	7	8	9	10	11
1	UP	UP	UP	UP	UP	dn
2	UP	UP	UP	UP	dn	UP
3	UP	UP	UP	UP	dn	dn
4	UP	UP	UP	dn	UP	UP
5	UP	UP	UP	dn	UP	dn
6	UP	UP	UP	dn	dn	UP
7	UP	UP	UP	dn	dn	dn
8	UP	UP	dn	UP	UP	UP
9	UP	UP	dn	UP	UP	dn
10	UP	UP	dn	UP	dn	UP
11	UP	UP	dn	UP	dn	dn
12	UP	UP	dn	dn	UP	UP
13	UP	UP	dn	dn	UP	dn
14	UP	UP	dn	dn	dn	UP
15	UP	UP	dn	dn	dn	dn
16	UP	dn	UP	UP	UP	UP
17	UP	dn	UP	UP	UP	dn
18	UP	dn	UP	UP	dn	UP
19	UP	dn	UP	UP	dn	dn
20	UP	dn	UP	dn	UP	UP
21	UP	dn	UP	dn	UP	dn
22	UP	dn	UP	dn	dn	UP
23	UP	dn	UP	dn	dn	dn
24	UP	dn	dn	UP	UP	UP
25	UP	dn	dn	UP	UP	dn
26	UP	dn	dn	UP	dn	UP
27	UP	dn	dn	UP	dn	dn
28	UP	dn	dn	dn	UP	UP
29	UP	dn	dn	dn	UP	dn
30	UP	dn	dn	dn	dn	UP
31	UP	dn	dn	dn	dn	dn
32	dn	UP	UP	UP	UP	UP

BIT VALUE: 32 16 8 4 2 1

5711/5711WM Door/Window Transmitter

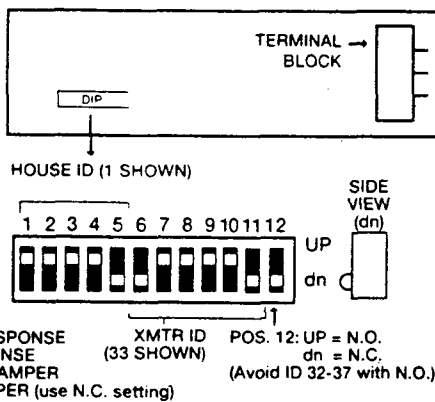

XMTR ID	DIP SWITCH SETTINGS				
XMTR ID	6	7	8	9	10
33	dn	UP	UP	UP	UP
34	dn	UP	UP	UP	dn
35	dn	UP	UP	dn	UP
36	dn	UP	UP	dn	dn
37	dn	UP	UP	dn	dn
38	dn	UP	dn	UP	UP
39	dn	UP	dn	UP	dn
40	dn	UP	dn	UP	dn
41	dn	UP	dn	UP	dn
42	dn	UP	dn	dn	UP
43	dn	UP	dn	dn	dn
44	dn	UP	dn	dn	UP
45	dn	UP	dn	dn	dn
46	dn	UP	dn	dn	dn
47	dn	UP	dn	dn	dn
48	dn	dn	UP	UP	UP
49	dn	dn	UP	UP	dn
50	dn	dn	UP	UP	dn
51	dn	dn	UP	UP	dn
52	dn	dn	UP	dn	UP
53	dn	dn	UP	dn	dn
54	dn	dn	UP	dn	dn
55	dn	dn	UP	dn	dn
56	dn	dn	dn	UP	UP
57	dn	dn	dn	UP	UP
58	dn	dn	dn	UP	dn
59	dn	dn	dn	UP	dn
60	dn	dn	dn	dn	UP
61	dn	dn	dn	dn	UP
62	dn	dn	dn	dn	UP
63	dn	dn	dn	dn	dn

BIT VALUE: 32 16 8 4 2 1

5716 Door/Window Transmitter

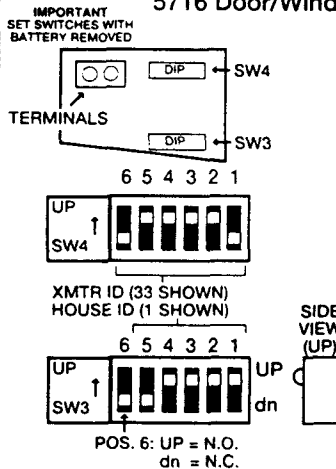

HOUSE ID	DIP SWITCH SETTINGS				
HOUSE ID	5	4	3	2	1
1	dn	UP	UP	UP	UP
2	dn	UP	UP	UP	dn
3	dn	UP	UP	dn	UP
4	dn	UP	UP	dn	dn
5	dn	UP	dn	UP	UP
6	dn	UP	dn	UP	dn
7	dn	UP	dn	UP	dn
8	dn	UP	dn	dn	UP
9	dn	UP	dn	dn	dn
10	dn	UP	dn	dn	UP
11	dn	UP	dn	dn	dn
12	dn	UP	dn	dn	UP
13	dn	UP	dn	dn	dn
14	dn	UP	dn	dn	UP
15	dn	UP	dn	dn	dn
16	dn	UP	dn	dn	UP
17	dn	UP	dn	dn	dn
18	dn	UP	dn	dn	UP
19	dn	UP	dn	dn	dn
20	dn	UP	dn	dn	UP
21	dn	UP	dn	dn	dn
22	dn	UP	dn	dn	UP
23	dn	UP	dn	dn	dn
24	dn	UP	dn	dn	UP
25	dn	UP	dn	dn	dn
26	dn	UP	dn	dn	UP
27	dn	UP	dn	dn	dn
28	dn	UP	dn	dn	UP
29	dn	UP	dn	dn	dn
30	dn	UP	dn	dn	UP
31	dn	UP	dn	dn	dn
32	dn	UP	dn	dn	UP
33	dn	UP	dn	dn	dn
34	dn	UP	dn	dn	UP
35	dn	UP	dn	dn	dn
36	dn	UP	dn	dn	UP
37	dn	UP	dn	dn	dn
38	dn	UP	dn	dn	UP
39	dn	UP	dn	dn	dn
40	dn	UP	dn	dn	UP
41	dn	UP	dn	dn	dn
42	dn	UP	dn	dn	UP
43	dn	UP	dn	dn	dn
44	dn	UP	dn	dn	UP
45	dn	UP	dn	dn	dn
46	dn	UP	dn	dn	UP
47	dn	UP	dn	dn	dn
48	dn	UP	dn	dn	UP
49	dn	UP	dn	dn	dn
50	dn	UP	dn	dn	UP
51	dn	UP	dn	dn	dn
52	dn	UP	dn	dn	UP
53	dn	UP	dn	dn	dn
54	dn	UP	dn	dn	UP
55	dn	UP	dn	dn	dn
56	dn	UP	dn	dn	UP
57	dn	UP	dn	dn	dn
58	dn	UP	dn	dn	UP
59	dn	UP	dn	dn	dn
60	dn	UP	dn	dn	UP
61	dn	UP	dn	dn	dn
62	dn	UP	dn	dn	UP
63	dn	UP	dn	dn	dn

BIT VALUE: 1 2 4 8 16

TRANSMITTER ID	DIP SWITCH SETTINGS					
TRANSMITTER ID	6	5	4	3	2	1
1	dn	UP	UP	UP	UP	UP
2	dn	UP	UP	UP	UP	dn
3	dn	UP	UP	UP	dn	UP
4	dn	UP	UP	UP	dn	dn
5	dn	UP	UP	dn	UP	UP
6	dn	UP	UP	dn	UP	dn
7	dn	UP	UP	dn	dn	UP
8	dn	UP	UP	dn	dn	dn
9	dn	UP	UP	dn	dn	UP
10	dn	UP	UP	dn	dn	dn
11	dn	UP	UP	dn	dn	UP
12	dn	UP	UP	dn	dn	dn
13	dn	UP	UP	dn	dn	UP
14	dn	UP	UP	dn	dn	dn
15	dn	UP	UP	dn	dn	UP
16	dn	UP	UP	dn	dn	dn
17	dn	UP	UP	dn	dn	UP
18	dn	UP	UP	dn	dn	dn
19	dn	UP	UP	dn	dn	UP
20	dn	UP	UP	dn	dn	dn
21	dn	UP	UP	dn	dn	UP
22	dn	UP	UP	dn	dn	dn
23	dn	UP	UP	dn	dn	UP
24	dn	UP	UP	dn	dn	dn
25	dn	UP	UP	dn	dn	UP
26	dn	UP	UP	dn	dn	dn
27	dn	UP	UP	dn	dn	UP
28	dn	UP	UP	dn	dn	dn
29	dn	UP	UP	dn	dn	UP
30	dn	UP	UP	dn	dn	dn
31	dn	UP	UP	dn	dn	UP
32	dn	UP	UP	dn	dn	dn
33	dn	UP	UP	dn	dn	UP
34	dn	UP	UP	dn	dn	dn
35	dn	UP	UP	dn	dn	UP
36	dn	UP	UP	dn	dn	dn
37	dn	UP	UP	dn	dn	UP
38	dn	UP	UP	dn	dn	dn
39	dn	UP	UP	dn	dn	UP
40	dn	UP	UP	dn	dn	dn
41	dn	UP	UP	dn	dn	UP
42	dn	UP	UP	dn	dn	dn
43	dn	UP	UP	dn	dn	UP
44	dn	UP	UP	dn	dn	dn
45	dn	UP	UP	dn	dn	UP
46	dn	UP	UP	dn	dn	dn
47	dn	UP	UP	dn	dn	UP
48	dn	UP	UP	dn	dn	dn
49	dn	UP	UP	dn	dn	UP
50	dn	UP	UP	dn	dn	dn
51						

GEL LEAD ACID TYPE.
DO NOT USE GATES BATTERY.
BATTERY NORMALLY NEED NOT BE
REPLACED FOR AT LEAST 3 YRS.
BATTERY CAPACITY FOR EMERGENCY
STANDBY USE AT LEAST 4 HOURS.

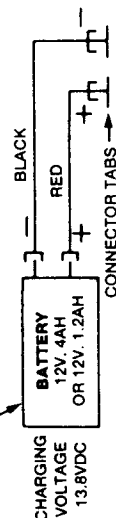

FUSES
FOR REPLACEMENT,
USE SAME VALUES

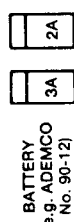

OPTIONAL (ANY ONE OF THESE)

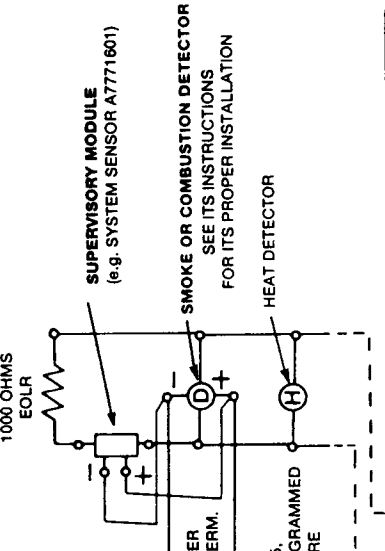
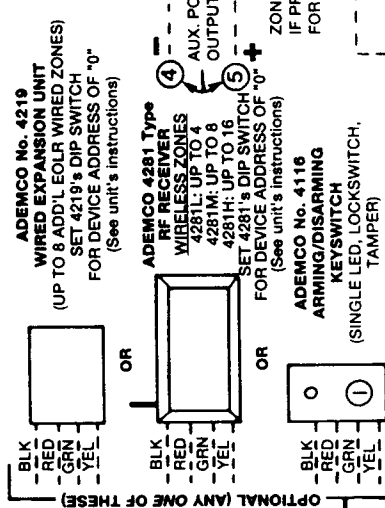

TO DETERMINE TOTAL STANDBY LOAD
ON BATTERY, ADD 100mA TO TOTAL OF
AUX. POWER OUTPUT AND REMOTE
KEYPAD CURRENTS.

USE UL LISTED LIMITED
ENERGY CABLE FOR
ALL CONNECTIONS

FOR COMPLETE
INFORMATION,
SEE INSTRUCTIONS

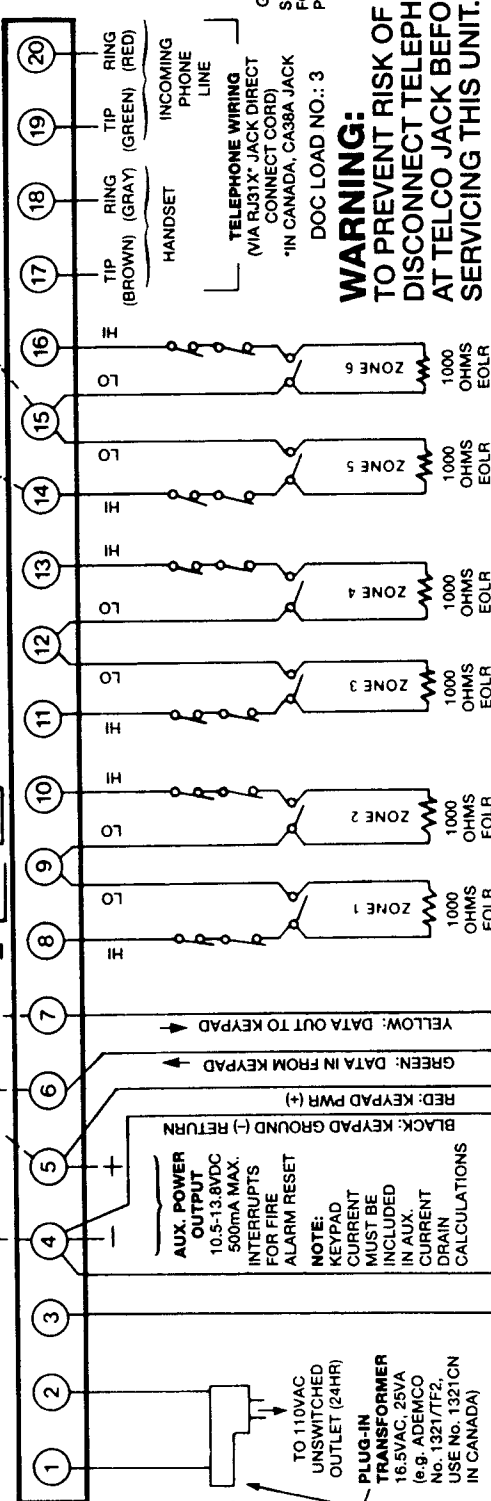

WARNING:
TO PREVENT RISK OF SHOCK,
DISCONNECT TELEPHONE LINE
AT TELCO JACK BEFORE
SERVICING THIS UNIT.

THIS EQUIPMENT SHOULD BE INSTALLED IN
ACCORDANCE WITH THE NATIONAL FIRE
PROTECTION ASSOCIATION'S STANDARD 74
(NATIONAL FIRE PROTECTION ASSOC.,
BATTERYMARCH PARK, QUINCY, MA 02269).
PRINTED INFORMATION DESCRIBING PROPER
INSTALLATION, OPERATION, TESTING,
MAINTENANCE, EVACUATION PLANNING AND
REPAIR SERVICE IS TO BE PROVIDED WITH
THIS EQUIPMENT.

- MAXIMUM LOOP RESISTANCE (EACH ZONE) 300 OHMS (PLUS EOLR)
- RESPONSE, ZONES 1-6: 300-500MSEC
- ZONE 3 CAN BE PROGRAMMED FOR N.C. SENSOR
- FAST RESPONSE TO AN OPEN: 10MSEC MAX
- ZONE 5 CAN BE PROGRAMMED FOR USE AS A FIRE ZONE. SEE DIAGRAM.

COMPLIES WITH FCC RULES, PART 68
FCC REGISTRATION NO. AC398U-68192-AL-E
RINGER EQUIVALENCE: 0.7B

THIS DEVICE COMPLIES WITH PART 15 OF FCC RULES.
OPERATION IS SUBJECT TO THE FOLLOWING TWO
CONDITIONS: (1) IT MAY NOT CAUSE HARMFUL INTERFERENCE
(2) IT MUST ACCEPT ANY INTERFERENCE THAT MAY CAUSE
UNDESIRABLE OPERATION.

ALARM OUTPUT
10.5-13.8VDC, 2A MAX.
(600mA MAX FOR UL USAGE,
INCLUDING AUX. POWER)
STEADY FOR BURGLARY/PANIC,
PULSING FOR FIRE (e.g. USE
ADEMCO No. 740 SOUNDER,
No. 702 OR 719 SIREN, OR 12V BELL
CONNECTION OF THE FIRE ALARM SIGNAL TO A FIRE ALARM
HEADQUARTERS OR A CENTRAL STATION SHALL BE PERMITTED
ONLY WITH THE PERMISSION OF THE LOCAL AUTHORITY HAVING
JURISDICTION. THE BURGLAR ALARM SIGNAL SHALL NOT BE
CONNECTED TO A POLICE EMERGENCY NUMBER.

NOTE: MULTIPLE KEYPADS
MAY BE USED, BUT
EACH 5330 KEYPAD
MUST BE ON AN INDI-
VIDUAL HOME RUN.
USE MAX. OF 220FT. OF
#22 WIRE OR 550FT. OF
#18 WIRE.

WEEKLY TESTING IS REQUIRED TO ENSURE
PROPER OPERATION OF THIS SYSTEM.

FA120C SUMMARY OF CONNECTIONS

UL NOTICE: This is a "Grade A" residential system.

FEDERAL COMMUNICATIONS COMMISSION (FCC) Part 15 STATEMENT

This equipment has been tested to FCC requirements and has been found acceptable for use. The FCC requires the following statement for your information:

This equipment generates and uses radio frequency energy and if not installed and used properly, that is, in strict accordance with the manufacturer's instructions, may cause interference to radio and television reception. It has been type tested and found to comply with the limits for a Class B computing device in accordance with the specifications in Part 15 of FCC Rules, which are designed to provide reasonable protection against such interference in a residential installation. However, there is no guarantee that interference will not occur in a particular installation. If this equipment does cause interference to radio or television reception, which can be determined by turning the equipment off and on, the user is encouraged to try to correct the interference by one or more of the following measures:

- If using an indoor antenna, have a quality outdoor antenna installed.
- Reorient the receiving antenna until interference is reduced or eliminated.
- Move the radio or television receiver away from the receiver/control.
- Move the antenna leads away from any wire runs to the receiver/control.
- Plug the receiver/control into a different outlet so that it and the radio or television receiver are on different branch circuits.

If necessary, the user should consult the dealer or an experienced radio/television technician for additional suggestions. The user or installer may find the following booklet prepared by the Federal Communications Commission helpful:

"Interference Handbook"

This booklet is available from the U.S. Government Printing Office, Washington, DC 20402.

The user shall not make any changes or modifications to the equipment unless authorized by the Installation Instructions or User's Manual. Unauthorized changes or modifications could void the user's authority to operate the equipment.

FEDERAL COMMUNICATIONS COMMISSION (FCC) Part 68 STATEMENT

This equipment complies with Part 68 of the FCC rules. On the front cover of this equipment is a label that contains, among other information, the FCC registration number and ringer equivalence number (REN) for this equipment. If requested, this information must be provided to the telephone company.

This equipment uses the following jacks: An RJ31X is used to connect this equipment to the telephone network.

The REN is used to determine the quantity of devices which may be connected to the telephone line. Excessive RENs on the telephone line may result in the devices not ringing in response to an incoming call. In most, but not all areas, the sum of the RENs should not exceed five (5.0). To be certain of the number of devices that may be connected to the line, as determined by the total RENs, contact the telephone company to determine the maximum REN for the calling area.

If this equipment causes harm to the telephone network, the telephone company will notify you in advance that temporary discontinuance of service may be required. If advance notice is not practical, the telephone company will notify the customer as soon as possible. Also, you will be advised of your right to file a complaint with the FCC if you believe necessary.

The telephone company may make changes in its facilities, equipment, operations, or procedures that could affect the operation of the equipment. If this happens, the telephone company will provide advance notice in order for you to make the necessary modifications in order to maintain uninterrupted service.

If trouble is experienced with this equipment, please contact the manufacturer for repair and warranty information. If the trouble is causing harm to the telephone network, the telephone company may request you remove the equipment from the network until the problem is resolved.

There are no user serviceable components in this product, and all necessary repairs must be made by the manufacturer. Other repair methods may invalidate the FCC registration on this product.

This equipment cannot be used on telephone company-provided coin service. Connection to Party Line Service is subject to state tariffs.

This equipment is hearing-aid compatible.

When programming or making test calls to an emergency number, briefly explain to the dispatcher the reason for the call. Perform such activities in the off-peak hours; such as early morning or late evening.

CANADIAN DEPARTMENT OF COMMUNICATIONS (DOC) STATEMENT

NOTICE

The Canadian Department of Communications label identifies certified equipment. This certification means that the equipment meets certain telecommunications network protective, operational and safety requirements. The Department does not guarantee the equipment will operate to the user's satisfaction.

Before installing this equipment, users should ensure that it is permissible to be connected to the facilities of the local telecommunications company. The equipment must also be installed using an acceptable method of connection. In some cases, the company's inside wiring associated with a single line individual service may be extended by means of certified connector assembly (telephone extension cord). The customer should be aware that compliance with the above conditions may not prevent degradation of service in some situations.

Repairs to certified equipment should be made by an authorized Canadian maintenance facility designated by the supplier. Any repairs or alterations made by the user to this equipment, or equipment malfunctions, may give the telecommunications company cause to request the user to disconnect the equipment.

Users should ensure for their own protection that the electrical ground connections of the power utility, telephone lines and internal metallic water pipe system, if present, are connected together. This precaution may be particularly important in rural areas.

Caution: User should not attempt to make such connections themselves, but should contact the appropriate electric inspection authority, or electrician, as appropriate.

The Load Number (LN) assigned to each terminal device denotes the percentage of the total load to be connected to a telephone loop which is used by the device, to prevent overloading. The termination on a loop may consist of any combination of devices subject only to the requirement that the total of the Load Numbers of all the devices does not exceed 100.

AVIS

L'étiquette du ministère des Communications du Canada identifie le matériel homologué. Cette étiquette certifie que le matériel est conforme à certaines normes de protection, d'exploitation et de sécurité des réseaux de télécommunications. Le ministère n'assure toutefois pas que le matériel fonctionnera à la satisfaction de l'utilisateur.

Avant d'installer ce matériel, l'utilisateur doit s'assurer qu'il est permis de le raccorder aux installations de l'entreprise locale de télécommunications. Le matériel doit également être installé en suivant une méthode acceptée de raccordement. Dans certains cas, les fils intérieurs de l'entreprise utilisés pour un service individuel à la ligne unique peuvent être prolongés au moyen d'un dispositif homologué de raccordement (cordon prolongateur téléphonique interne). L'abonné ne doit pas oublier qu'il est possible que la conformité aux conditions énoncées ci-dessus n'empêche pas la dégradation du service dans certaines situations. Actuellement, les entreprises de télécommunications ne permettent pas que l'on raccorde leur matériel aux prises d'abonnés, sauf dans les cas précis prévus par les tarifs particuliers de ces entreprises.

Les réparations du matériel homologué doivent être effectuées par un centre d'entretien canadien autorisé désigné par le fournisseur. La compagnie de télécommunications peut demander à l'utilisateur de débrancher un appareil à la suite de réparations ou de modifications effectuées par l'utilisateur ou à cause de mauvais fonctionnement.

Pour sa propre protection, l'utilisateur doit s'assurer que tous les fils de mise en terre de la source d'énergie électrique, des lignes téléphoniques de réseau de conduites d'eau, s'il y en a, soient raccordés ensemble. Cette précaution est particulièrement importante dans les régions rurales.

Avertissement: L'utilisateur ne doit pas tenter de faire ces raccordements lui-même; il doit avoir recours à un service d'inspection des installations électriques, ou à un électricien, selon le cas.

L'indice de charge (IC) assigné à chaque dispositif terminal pour éviter toute surcharge indique le pourcentage de la charge totale qui peut être raccordé à un circuit téléphonique bouclé utilisé par ce dispositif. La terminaison du circuit bouclé peut être constituée de n'importe quelle combinaison de dispositifs, pourvu que la somme des indices de charge de l'ensemble des dispositifs ne dépasse pas 100.

WARNING

THE LIMITATIONS OF THIS ALARM SYSTEM

While this System is an advanced design security system, it does not offer guaranteed protection against burglary, fire or other emergency. Any alarm system, whether commercial or residential, is subject to compromise or failure to warn for a variety of reasons. For example:

- Intrusion detectors (e.g., passive infrared detectors), smoke detectors, and many other sensing devices will not work without power. Battery-operated devices will not work without batteries, with dead batteries, or if the batteries are not put in properly. Devices powered solely by AC will not work if their AC power supply is cut off for any reason, however briefly.
- Signals sent by wireless transmitters may be blocked or reflected by metal before they reach the alarm receiver. Even if the signal path has been recently checked during a weekly test, blockage can occur if a metal object is moved into the path.
- A user may not be able to reach a panic or emergency button quickly enough.
- While smoke detectors have played a key role in reducing residential fire deaths in the United States, they may not activate or provide early warning for a variety of reasons in as many as 35% of all fires, according to data published by the Federal Emergency Management Agency. Some of the reasons smoke detectors used in conjunction with this System may not work are as follows. Smoke detectors may have been improperly installed and positioned. Smoke detectors may not sense fires that start where smoke cannot reach the detectors, such as in chimneys, in walls, or roofs, or on the other side of closed doors. Smoke detectors also may not sense a fire on another level of a residence or building. A second floor detector, for example, may not sense a first floor or basement fire. Finally, smoke detectors have sensing limitations. No smoke detector can sense every kind of fire every time. In general, detectors may not always warn about fires caused by carelessness and safety hazards like smoking in bed, violent explosions, escaping gas, improper storage of flammable materials, overloaded electrical circuits, children playing with matches, or arson. Depending on the nature of the fire and/or location of the smoke detectors, the detector, even if it operates as anticipated, may not provide sufficient warning to allow all occupants to escape in time to prevent injury or death.
- Passive Infrared Motion Detectors can only detect intrusion within the designed ranges as diagrammed in their installation manual. Passive Infrared Detectors do not provide volumetric area protection. They do create multiple beams of protection, and intrusion can only be detected in unobstructed areas covered by those beams. They cannot detect motion or intrusion that takes place behind walls, ceilings, floors, closed doors, glass partitions, glass doors, or windows. Mechanical tampering, masking, painting or spraying of any material on the mirrors, windows or any part of the optical system can reduce their detection ability. Passive Infrared Detectors sense changes in temperature; however, as the ambient temperature of the protected area approaches the temperature range of 90° to 105°F (32° to 40°C), the detection performance can decrease.
- Alarm warning devices such as sirens, bells or horns may not alert people or wake up sleepers if they are located on the other side of closed or partly open doors. If warning devices are located on a different level of the residence from the bedrooms, then they are less likely to waken or alert people inside the bedrooms. Even persons who are awake may not hear the warning if the alarm is muffled by noise from a stereo, radio, air conditioner or other appliance, or by passing traffic. Finally, alarm warning devices, however loud, may not warn hearing-impaired people.
- Telephone lines needed to transmit alarm signals from a premises to a central monitoring station may be out of service or temporarily out of service. Telephone lines are also subject to compromise by sophisticated intruders.
- Even if the system responds to the emergency as intended, however, occupants may have insufficient time to protect themselves from the emergency situation. In the case of a monitored alarm system, authorities may not respond appropriately.
- This equipment, like other electrical devices, is subject to component failure. Even though this equipment is designed to last as long as 20 years, the electronic components could fail at any time.

The most common cause of an alarm system not functioning when an intrusion or fire occurs is inadequate maintenance. This alarm system should be tested weekly to make sure all sensors and transmitters are working properly. The security console (and remote keypad) should be tested as well.

Wireless transmitters (used in some systems) are designed to provide long battery life under normal operating conditions. Longevity of batteries may be as much as 4 to 7 years, depending on the environment, usage, and the specific wireless device being used. External factors such as humidity, high or low temperatures, as well as large swings in temperature, may all reduce the actual battery life in a given installation. This wireless system, however, can identify a true low battery situation, thus allowing time to arrange a change of battery to maintain protection for that given point within the system.

Installing an alarm system may make the owner eligible for a lower insurance rate, but an alarm system is not a substitute for insurance. Homeowners, property owners and renters should continue to act prudently in protecting themselves and continue to insure their lives and property.

We continue to develop new and improved protection devices. Users of alarm systems owe it to themselves and their loved ones to learn about these developments.

3 YEAR LIMITED WARRANTY

Pittway Corporation, and its divisions, subsidiaries and affiliates ("Seller"), 165 Eileen Way, Syosset, New York 11791, warrants its First Alert products to be in conformance with its own plans and specifications and to be free from defects in materials and workmanship under normal use and service for 36 months from the date stamp control on the product or, for products not having a date stamp, for 30 months from date of original purchase unless the installation instructions or catalog sets forth a shorter period, in which case the shorter period shall apply. Seller's obligation shall be limited to repairing or replacing, at its option, free of charge for materials or labor, any product which is proved not in compliance with Seller's specifications or proves defective in materials or workmanship under normal use and service. Seller shall have no obligation under this Limited Warranty or otherwise if the product is altered or improperly repaired or serviced by anyone other than First Alert factory service. For warranty service, return product transportation prepaid, to First Alert Factory Service, 165 Eileen Way, Syosset, New York 11791.

THERE ARE NO WARRANTIES, EXPRESS OR IMPLIED, OF MERCHANTABILITY, OR FITNESS FOR A PARTICULAR PURPOSE OR OTHERWISE, WHICH EXTEND BEYOND THE DESCRIPTION ON THE FACE HEREOF. IN NO CASE SHALL SELLER BE LIABLE TO ANYONE FOR ANY CONSEQUENTIAL OR INCIDENTAL DAMAGES FOR BREACH OF THIS OR ANY OTHER WARRANTY, EXPRESS OR IMPLIED, OR UPON ANY OTHER BASIS OF LIABILITY WHATSOEVER, EVEN IF THE LOSS OR DAMAGE IS CAUSED BY THE SELLER'S OWN NEGLIGENCE OR FAULT.

Seller does not represent that the products it sells may not be compromised or circumvented; that the products will prevent any personal injury or property loss by burglary, robbery, fire or otherwise; or that the products will in all cases provide adequate warning or protection. Customer understands that a properly installed and maintained alarm may only reduce the risk of a burglary, robbery, fire or other events occurring without providing an alarm, but it is not insurance or a guarantee that such will not occur or that there will be no personal injury or property loss as a result. CONSEQUENTLY, SELLER SHALL HAVE NO LIABILITY FOR ANY PERSONAL INJURY, PROPERTY DAMAGE OR OTHER LOSS BASED ON A CLAIM THE PRODUCT FAILED TO GIVE WARNING. HOWEVER, IF SELLER IS HELD LIABLE, WHETHER DIRECTLY OR INDIRECTLY, FOR ANY LOSS OR DAMAGE ARISING UNDER THIS LIMITED WARRANTY OR OTHERWISE, REGARDLESS OF CAUSE OR ORIGIN, SELLER'S MAXIMUM LIABILITY SHALL NOT IN ANY CASE EXCEED THE PURCHASE PRICE OF THE PRODUCT, WHICH SHALL BE THE COMPLETE AND EXCLUSIVE REMEDY AGAINST SELLER. This warranty replaces any previous warranties and is the only warranty made by Seller on this product. No increase or alteration, written or verbal, of the obligations of this Limited Warranty is authorized.



N6101-1V1 8/93

A DIVISION OF PITTHWAY CORP.
172 Michael Drive
Syosset, New York 11791

COPYRIGHT © 1991 PITTHWAY CORPORATION